

# LECTURE NOTES

For Environmental Health Science Students

# *Surveying*



**Ethiopia Public Health  
Training Initiative**

Wuttiet Tafesse,  
Tesfaye Gobena

Haramaya University

In collaboration with the Ethiopia Public Health Training Initiative, The Carter Center,  
the Ethiopia Ministry of Health, and the Ethiopia Ministry of Education

2005



Funded under USAID Cooperative Agreement No. 663-A-00-00-0358-00.

Produced in collaboration with the Ethiopia Public Health Training Initiative, The Carter Center, the Ethiopia Ministry of Health, and the Ethiopia Ministry of Education.

**Important Guidelines for Printing and Photocopying**

Limited permission is granted free of charge to print or photocopy all pages of this publication for educational, not-for-profit use by health care workers, students or faculty. All copies must retain all author credits and copyright notices included in the original document. Under no circumstances is it permissible to sell or distribute on a commercial basis, or to claim authorship of, copies of material reproduced from this publication.

**©2005 by Wuttiet Tafesse, Tesfaye Gobena**

All rights reserved. Except as expressly provided above, no part of this publication may be reproduced or transmitted in any form or by any means, electronic or mechanical, including photocopying, recording, or by any information storage and retrieval system, without written permission of the author or authors.

*This material is intended for educational use only by practicing health care workers or students and faculty in a health care field.*

## Preface

This lecture note is prepared for Environmental Health Science Students who need to understand measurement of distances, angles and other similar activities. It is designed to give the student the basic concepts and skills of surveying for undergraduate level. This material could have paramount importance for the health professionals who are involved in public health activities.

Public health students are frequently involved in community diagnosis, one of the major activities of public health. This activity requires, among other things, drawing of sketch maps of the area in question. A basic knowledge of surveying is of great help for planning, designing, layout and construction of different sanitary facilities.

In Ethiopia there are no textbooks, which could appropriately fulfill the requirements of surveying course for Environmental Health Science students. We believe that this lecture note can fill that gap.

This lecture note is divided in to nine chapters. Each chapter comprises of learning objectives, introduction, and practical exercises.

## Acknowledgement

We would like to acknowledge The Carter Center for the financial support to the workshop conducted to develop the lecture note. We would also like to thank Alemaya University, Faculty of Health Sciences academic staff members for reviewing the manuscript in the intra-institutional workshop. Our deep appreciation also goes to Essayas Alemayehu , Ato Zeleke Alebachew , Ato adane Sewuhunegn, Ato Embialle Mengistie and Ato Yonas Mamo who gave valuable comments during the inter-institutional workshop.

## Table of Contents

Preface .....	i
Acknowledgement.....	ii
Table of Contents.....	iii
List of figures.....	vi
Acronyms .....	ix
<b>CHAPTER ONE: Introduction To Surveying</b>	
1.1. Learning objectives.....	1
1.2. Introduction.....	1
1.3. Definition and Technical Terms.....	2
1.4. Importance of surveying .....	2
1.5. Application of Surveying in Environmental Health Activities .....	3
Exercise .....	4
<b>CHAPTER TWO: The Basic Surveying Methods</b>	
2.1. Learning Objectives.....	5
2.2. Introduction.....	5
2.3. Measuring Distances and Angles.....	7
2.4. Types of Surveying.....	9
2.5. Surveying Applications .....	11
2.6. Field Notes.....	14
Exercise .....	15
<b>CHAPTER THREE: Measurements and Computations</b>	
3.1. Learning Objectives.....	16
3.2. Introduction.....	16
3.3. Types of Measurements in Surveying.....	17

3.4. Significant Figures .....	20
3.5. Mistakes and Errors.....	23
3.6. Accuracy and Precision .....	29
Exercise .....	34
<b>CHAPTER FOUR: Measuring Horizontal Distances</b>	
4.1. Learning Objectives .....	37
4.2. Introduction .....	37
4.3. Rough Distance Measurement .....	38
4.4. Taping Equipments and Methods.....	41
Exercise .....	57
<b>CHAPTER FIVE: Leveling</b>	
5.1. Learning Objectives .....	60
5.2. Introduction .....	60
5.3. Measuring Vertical Distances .....	61
5.4. Methods of Leveling .....	61
5.5. Benchmarks and Turning Points .....	65
5.6. Inverted Staff Reading .....	68
5.7. Reciprocal Leveling .....	69
5.8. Leveling Equipment .....	70
5.9. Leveling Procedures.....	76
5.10. Profile Leveling .....	90
5.11. Cross-Section Leveling.....	93
5.12. Three-Wire Leveling .....	95
Exercise .....	97
<b>CHAPTER SIX: Tachometry</b>	
6.1. Learning Objectives .....	102
6.2. Introduction .....	102
6.3. Principles of Stadia.....	102
6.4. Stadia Measurement on an inclined Sights ....	105

6.5. Sources of Errors in Stadia Work .....	108
Exercise .....	110
<b>CHAPTER SEVEN: Angles, Bearing and Azimuths</b>	
7.1. Learning objectives.....	112
7.2. Introduction .....	112
7.3. Angles.....	112
7.4. Direction of a Line.....	117
7.5. Azimuths .....	120
7.6. Compass Survey .....	124
Exercise .....	128
<b>CHAPTER THREE: Traversing</b>	
8.1. Learning Objectives .....	130
8.2. Introduction .....	130
8.3 Balancing Angles.....	132
8.4. Latitudes and Departures .....	133
8.5 Traverse Adjustment .....	136
8.6 Application Of Traversing .....	138
Exercise Error! Bookmark Not Defined .....	145
<b>CHAPTER NINE: Construction Surveys</b>	
9.1 Learning Objectives.....	150
9.2. Introduction .....	150
9.3. Setting out a Peg on a Specified Distance and Bearing .....	154
9.4. Setting Out Small Buildings .....	158
9.5. Sewer and Tunnel Construction .....	168
Exercise .....	172
GLOSSARY .....	173
REFERENCES.....	180

## LIST OF FIGURES

Fig. 2.1 Shape of the earth.....	6
Fig. 2.2 The vertical direction.....	7
Fig. 2.3 A true horizontal distance; is actually curved, like the surface of the earth.....	8
Fig. 2.4 Plane surveying.....	10
Fig. 3.1 Steel tape.....	18
Fig. 3.2 Illustration of accuracy and precision.....	21
Fig. 3.3 Illustration of accuracy and precision.....	30
Fig. 4.1 Pacing provides a simple yet useful way to make distance measurement.....	39
Fig. 4.2 A typical measuring wheel used for making rough distance measurements.....	40
Fig. 4.3 Fiber glass tapes (A) closed caes; (B) Open reel.....	42
Fig. 4.4 A pulb bob is one of the simplest yet most important accessories for accurate surveying ..	43
Fig. 4.5 A surveyor's range pole.....	43
Fig. 4.6 (a) Chaining pin (b) Keel.....	44
Fig. 4.7 Hand level.....	44
Fig. 4.8.....	45
Fig. 4.9 A tape clamp handle.....	46
Fig. 4.10 Breaking tape.....	47
Fig. 5.1 Differential leveling to measure vertical distance and elevation. (a) Step 1: take a back sight rod reading on point A (b) Step 2: rotate the telescope toward point Band take foresight rod reading.....	63



Fig. 5.2 Temporary turning points are used to carry a line of levels from a benchmark to some other station or benchmark; the process of differential leveling is repeated each instrument set up....	65
Table 5.1. Field book format for leveling notes .....	67
Fig. 5.3 Illustration of inverted staff reading .....	68
Table 5.2. Shows the reading observed to the points A, B, C, and D on the multistory building of figure 5.3 -Illustration of inverted staff reading	69
Fig 5.4 Dumpy level .....	71
Fig 5.5 Tilting level .....	71
Fig 5.6 Automatic levels .....	72
Fig.5.7 traditional rectangular cross section leveling rods showing a variety of graduation markings	75
Fig. 5.8 Circular rod level .....	76
Fig. 5.9 Tripod stands .....	77
Fig. 5.10 tripod head adaptor .....	77
Fig 5.11 Leveling a three-screw instrument.....	78
Fig 5. 12. When the horizontal length of the foresight (plus) and backsight (minus) are the same, the systematic error of adjustment of the level is cancelled .....	81
Fig. 5.13 Illustration of horizontal line and level surface departure.....	82
Fig. 6.1 Horizontal stadia measurement .....	103
Fig. 6.2. Inclined Stadia measurement .....	105
Fig. 7.1. The three determinants of an angle .....	113
Fig. 7.2. Theodolites.....	114

Fig. 7.3. Horizontal circle reading using optical micrometer .....	115
Fig. 7.4. Interior angles of a polygon.....	116
Fig. 7.5. Angles of the right .....	116
Fig. 7.6. Deflection angles.....	117
Fig.7.7 The bearing of a line is measured from the north or from the south .....	119
Fig. 7.8 Bearings .....	120
Fig 7.9 Azimuths .....	121
Fig. 7.10 Bearings and angles .....	123
Fig. 7.11 Declination east.....	125
Fig. 7.12 Declination set off on a compass circle .....	125
Fig. 8.1 Open traverse .....	131
Fig. 8.2 Closed traverse .....	132
Fig. 8.3 latitude and Departure .....	135
Fig. 8.4 Area by rectangular coordinates .....	140
Fig. 8.5 Meridian distances and areas .....	141
Fig. 8.6 Area by double meridian distances.....	142
Fig. 9.1. Setting out pegs and profiles .....	153
Fig 9.2. Setting out on level ground .....	155
Fig 9.3. Setting out small buildings .....	159
Fig. 9.4. Setting out the building .....	162
Fig. 9.5. Setting out instrument on sloping ground .....	163
Fig. 9.6. Setting out peg at a predetermined level .....	165

## ACRONYMS

<b>BM:</b>	Bench Mark
<b>EDM:</b>	Electronic Distance Measurement
<b>HI:</b>	Height of Instrument above a datum
<b>hi:</b>	Height of Instrument(optical axis) above the instrument station
<b>TP:</b>	Turning point
<b>DMD:</b>	Double Meridian Distance
<b>MSL:</b>	Mean Sea Level
<b>FS:</b>	Foresight
<b>BS:</b>	Backsight

# CHAPTER ONE

## INTRODUCTION TO SURVEYING

### 1.1. LEARNING OBJECTIVES

At the end of this chapter, students will be able to:

1. Define surveying and other technical terms
2. Describe the importance of surveying
3. know the application of surveying in environmental health activities.

### 1.2 INTRODUCTION

Surveying has been important since the beginning of civilization. Today, the importance of measuring and monitoring our environment is becoming increasingly critical as our population expands, land values appreciate, our natural resources dwindle, and human activities continue to pollute our land, water and air. As a result, the breadth and diversity of practice of surveying, as well as its importance in modern civilization is increasing from time to time.

***Surveying is a discipline, which encompasses all methods for measuring, processing, and disseminating information about the physical earth and our environment.***

### **1.3 Definition and Technical Terms**

Simply stating, *surveying* involves the measurement of distances and angles. The distance may be horizontal or vertical in direction. Vertical distances are also called *elevations*. Similarly, the angles may be measured in horizontal and vertical plane. Horizontal angles are used to express the directions of land boundaries and other lines.

There are two fundamental purposes for measuring distances and angles.

- ❖ The first is to determine the relative positions of existing points or objects on or near the surface of the earth.
- ❖ The second is to layout or mark the desired positions of new points or objects, which are to be placed or constructed on or near the surface of the earth.

Surveying measurements must be made with precision in order to achieve a maximum of accuracy with a minimum expenditure of time and money.

The practice of surveying is an art, because it is dependent up on the skills, judgments and experience of surveyor. It may also be considered as an applied science, because field and office procedures rely upon a systematic body of knowledge.

### **1.4 IMPORTANCE OF SURVEYING**

Surveying is one of the world's oldest and most important arts because, as noted previously, from the earliest times it has

been necessary to mark boundaries and divide land. Surveying has now become indispensable to our modern way of life. The results of today's surveys are being used to:

1. Map the earth above and below sea level.
2. Prepare navigational charts for use in the air, on land and at sea.
3. Establish property boundaries of private and public lands
4. Develop data banks of land-use and natural resources information which aid in managing our environment
5. Determine facts on the size, shape, gravity and magnetic fields of the earth and
6. Prepare charts of our moon and planets.

## **1.5 Application of Surveying in Environmental Health Activities**

Surveying plays an essential role in the planning, design, layout, and construction of our physical environment and infrastructure (all the constructed facilities and systems which human communities use to function and thrive productively). It is also the link between design and construction. Roads, bridges, buildings, water supply, sewerage, drainage systems, and many other essential public work projects could never have been built without surveying technology.

## Exercise

1. Give a brief definition of Surveying.
2. Describe the two fundamental purposes of surveying.
3. Briefly describe why surveying may be characterized as both an art and a science.
4. Why is surveying an important technical discipline?
5. Discuss the application of surveying in environmental health activities.

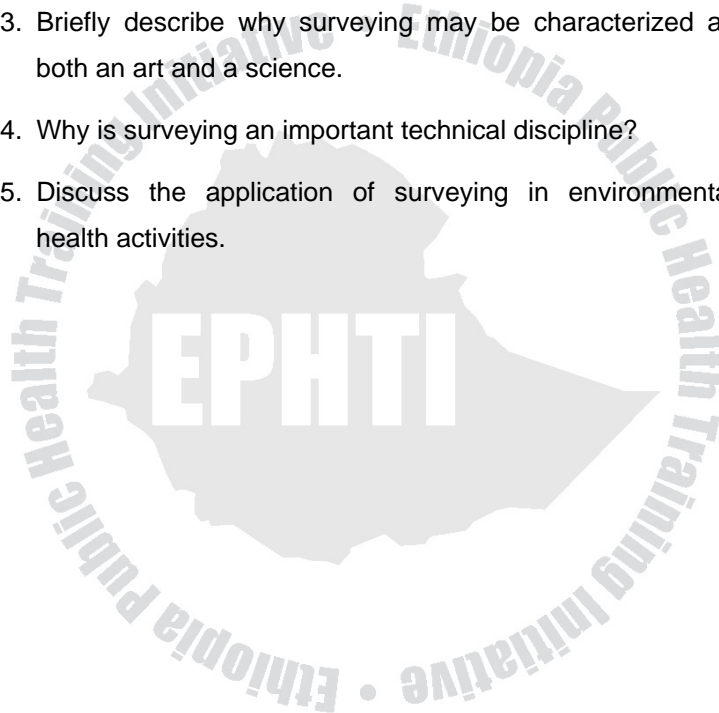

# **CHATER TWO**

## **THE BASIC SURVEYING METHODS**

### **2.1 LEARNING OBJECTIVES**

At the end of this chapter, students will be able to:

1. Identify and state the different types of surveying
2. Describe different surveying applications
3. Apply measurement of distances and angles
4. Describe the rules of field notes of a surveyor.

### **2.2 INTRODUCTION**

Most surveying activities are performed under the pseudo assumption that measurements are being made with reference to a flat horizontal surface. This requires some further explanation.

The earth actually has the approximate shape of a spheroid that is the solid generated by an ellipse rotated on its minor axis. However, for our purposes, we can consider the earth to be a perfect sphere with a constant diameter. In addition, we can consider that the average level of the ocean or mean sea levels represent the surface of sphere.



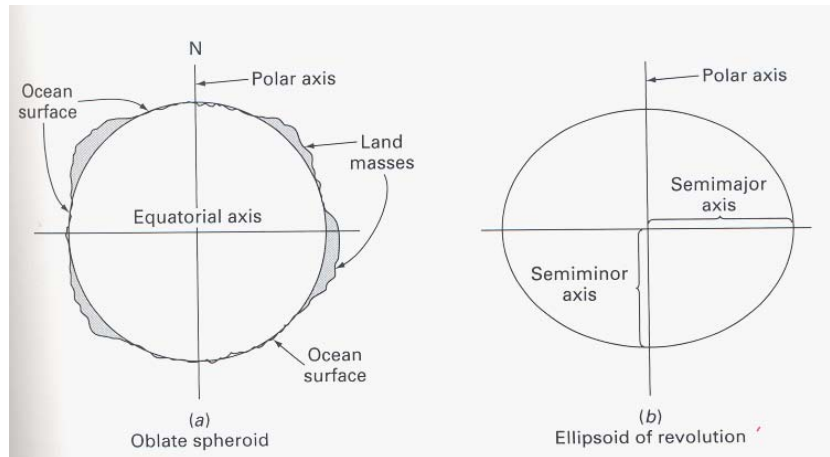

**Fig. 2.1.** Shape of the earth

By definition, the curved surface of a sphere is termed a *level surface*. The direction of gravity is perpendicular to this level surface at all points, and gravity is used as a reference direction for all surveying measurements. The *vertical direction* is taken to be the direction of gravity. In addition, the *horizontal direction* is the direction perpendicular to the vertical direction of gravity.

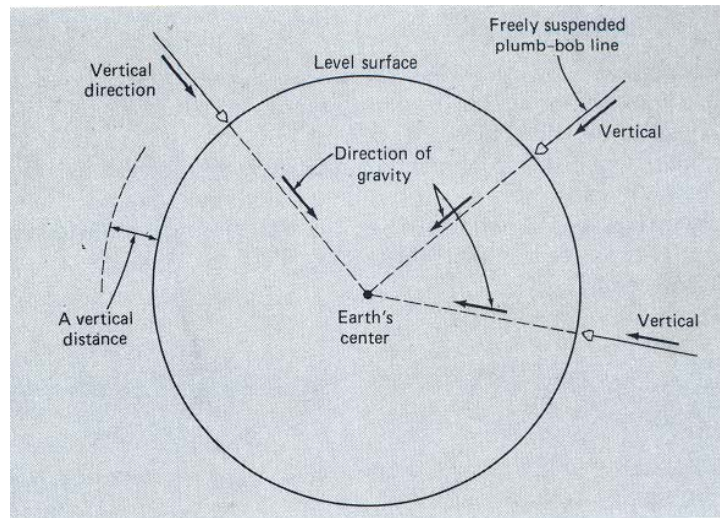

**Fig. 2.2.** The vertical direction is defined as the direction of the force of gravity.

## 2.3 MEASURING DISTANCES AND ANGLES

Horizontal distance is measured along a level surface. At every point along that length, the line tangent to the level surface is horizontal. It can be measured by tape or Electronic Distance Measurement (EDM). A true horizontal distance is actually curved, like the surface of the earth.

A vertical distance is measured along the direction of gravity and is equivalent to a difference in height between two points. When the height is measured with reference to a given level surface, like mean sea level, it is called an *elevation*. An

instrument called *level*, which is used to observe the rod at different points, can measure elevation. The relative vertical position of several points separated by long distances can be determined by a continuous series of level rod observations. This procedure is called leveling.

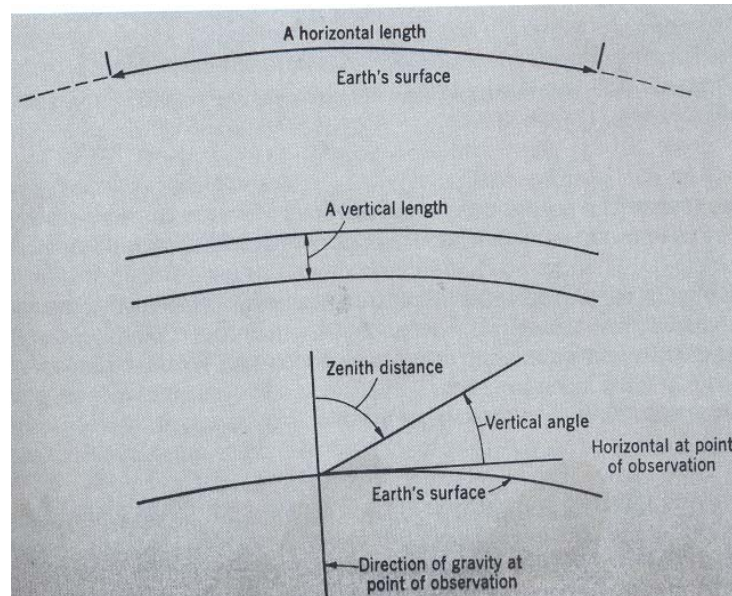

**Fig. 2.3.** A true horizontal distance is actually curved, like the surface of the earth.

A horizontal angle is measured in a plane that is horizontal at the point of measurement. When horizontal angle is measured between points, which do not lie directly in the plane, it is measured between the perpendiculars extended to the plane from those points.

A vertical angle is measured in a plane that is vertical at the point of observation or measurement. Horizontal and vertical angles are measured with an instrument called a *transit or theodolite*.

## 2.4 Types of Surveying

There are two types of surveying: these are

### 1. Plane surveying

As mentioned earlier that most surveying measurements are carried out as if the surface of the earth were perfectly flat. The method of surveying based on this assumption is called *plane surveying*. In plane surveying, it is neglect the curvature of the earth, and it is used the principles of plane geometry and plane trigonometry to compute the result of our surveys.

The use of plane surveying methods simplifies the work of surveyor. With in a distance of 20 km, the effect of earth's curvature on our measurement is so small that we can hardly measure it. In other words, a horizontal distance measured between two points along a truly level line is, for practical purposes, the same distances measured along the straight chord connecting the two points.

**N.B:** In plane surveying horizontal lines are assumed to be straight line and all vertical lines are parallel.

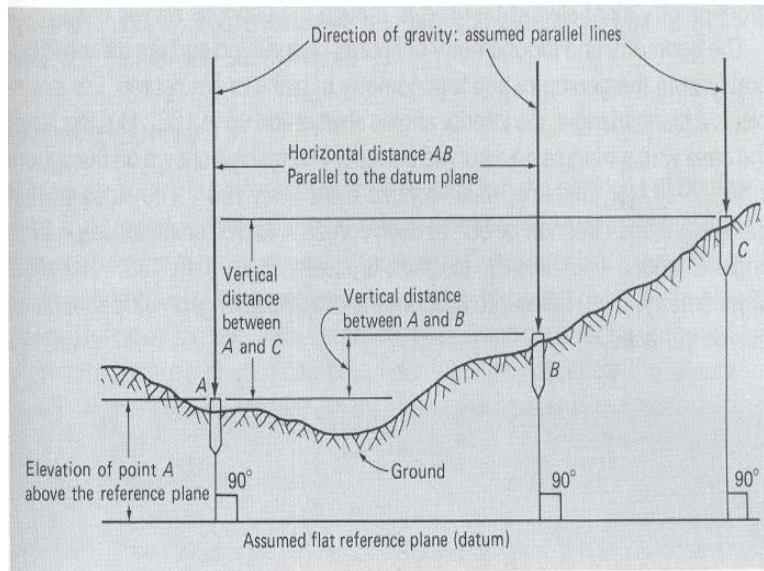

**Fig. 2.4.** In plane surveying, the curvature of the earth is neglected, and vertical distances are measured with reference of a flat plane.

## 2. Geodetic surveying

A surveying, which takes the earth's curvature into account is called Geodetic survey. These types of surveys are usually considered by agencies like Geological Survey. Geodetic surveying methods are generally used to map large areas and to establish large-scale networks of points on the earth for horizontal and vertical control.

## 2.5 SURVEYING APPLICATIONS

As mentioned earlier, the two fundamental purposes for surveying are to determine the relative positions of existing points and to mark the positions of new points on or near the surface of the earth. However, different types of surveys require different field procedures and varying degrees of precision for carrying out the work.

- **Property survey**

It is also called land survey or boundary survey. It is performed in order to establish the positions of boundary lines and property corners. It is usually performed whenever land ownership is to be transferred or when a large tract of land is to be subdivided in to smaller parcels for development. It is also performed before the design and construction of any public/private land-use project.

- **Topographic survey**

It is performed in order to determine the relative positions of existing natural and constructed features on a tract of land (like ground elevation, bodies of water, roads, buildings etc.). It provides information on the “shape of the land” hills, valleys, ridges and general slope of the ground. The data's obtained from a topographic surveys are plotted in a map called *topographic map* and the shape of the ground is shown with lines of equal elevation called *contours*.



- **Construction survey**

It is also called layout or location survey and performed in order to mark the positions of new points on the ground. These new points represent the location of building corners, road centerlines and other facilities that are to be built.

- **City survey**

The surveys which are carried out for the construction of roads, parks water supply system, sewer and other constructional work for any developing township, are called city surveys. The city maps which are prepared for tourists are known as guide maps.

- **Control survey**

There are two kinds of control surveys: These are horizontal and vertical control survey.

1. Horizontal control survey:

The surveyor, using temporary/permanent markers, places several points in the ground. These points, called stations, are arranged through out the site area under study so that it can be easily seen.

The relative horizontal positions of these points are established, usually with a very high degree of precisions and accuracy; this is done using transverse, triangulation or trilateration methods.

## 2. Vertical control survey

The elevations of relatively permanent reference points are determined by precise leveling methods. Marked points of known elevations are called elevation benchmarks. The network of stations and benchmarks provide a framework for horizontal and vertical control, up on which less accurate surveys can be based.

- **Route survey**

It is performed in order to establish horizontal and vertical controls, to obtain topographic data, and to layout the position of high ways, railroads, pipe lines etc. The primary aspect of route surveying is that the project area is very narrow compared with its length, which can extend for many kilometers.

- **Other types of surveys**

- ✓ **HYDRRAULIC SURVEY:** is a preliminary survey applied to a natural body of water, e.g. mapping of shorelines, harbor etc.
- ✓ **RECONNAISSANCE SURVEY:** is a preliminary survey conducted to get rough data regarding a tract of land.
- ✓ **PHOTOGRAMMETRIC SURVEYING:** uses relatively accurate methods to convert aerial photographs in to useful topographic maps.



## 2.5 FIELD NOTES

All surveys must be free from mistakes or blunders. A potential source of major mistakes in surveying practice is the careless or improper recording of field notes. The art of eliminating blunders is one of the most important elements in surveying practice.

### **RULES FOR FIELD NOTES**

1. Record all field data carefully in a field book at the moment they are determined.
2. All data should be checked at the time they are recorded.
3. An incorrect entry of measured data should be neatly lined out, the correct number entered next to or above it.
4. Field notes should not be altered, and even data that are crossed out should still remain legible.
5. Original field records should never be destroyed, even if they are copied for one reason to another.
6. A well-sharpened medium-hard pencil should be used for all field notes.
7. Sketches should be clearly labeled.
8. Show the word VOID on the top of pages that, for one reason or another, are invalid.
9. The field book should contain the name, address, and the phone number.
10. Each new survey should begin on a new page.
11. For each day of work, the project name, location, and date should be recorded in the upper corner of the right –hand page.

## Exercise

1. Define and briefly discuss the terms vertical and horizontal distance and angle.
2. Is a horizontal distance a perfect straight line? Why?
3. What is meant by the term elevation?
4. What does the term leveling mean?
5. What surveying instruments are used to measure angles and distances?
6. What is the basic assumption for plane surveying?
7. How does geodetic surveying differ from plane surveying?
8. Under what circumstances is it necessary to conduct a geodetic survey?
9. Give a brief description of the topographic and construction surveying.
10. Why is the proper recording of field notes a very important part of surveying practice?

# CHAPTER THREE

## MEASUREMENTS AND COMPUTATIONS

### 3.1 LEARNING OBJECTIVES

At the end of this chapter, the student will be able to:

1. Describe types of measurement in surveying
2. State the different types of errors in surveying
3. Identify and select instruments and procedures necessary to reduce errors

### 3.2 INTRODUCTION

Making measurements and subsequent computations and analyses using them are fundamental tasks of surveyors. The process requires a combination of human skill and mechanical equipment applied with the utmost judgment. No matter how carefully made, however, measurements are never exact and will always contain errors.

Surveyors, whose work must be performed to exacting standards, should therefore thoroughly understand the different kinds of errors, their sources and expected magnitudes under varying conditions, and their manner of propagation. Only then can they select instruments and procedures necessary to reduce error sizes to within tolerable limits.

### 3.3 TYPES OF MEASUREMENTS IN SURVEYING

There are five basic kinds of measurements in plane surveying:

1. Horizontal angles
2. Horizontal distance
3. Vertical angles
4. Vertical distance
5. Slope distance

By using combinations of these basic measurements it is possible to compute relation positions between any points.

Measurement of distances and angles it is the essence surveying.

Angle is simply figure formed by the intersection of two lines or figures generated by the rotation of a line about a point form an initial position to a terminal position. The point of rotation is called the vertex of the angle.

There are several systems of angle measurement. The most common ones are sexagesimal system and centesimal system

## A. The Sexagesimal System:

This system uses degrees, minutes

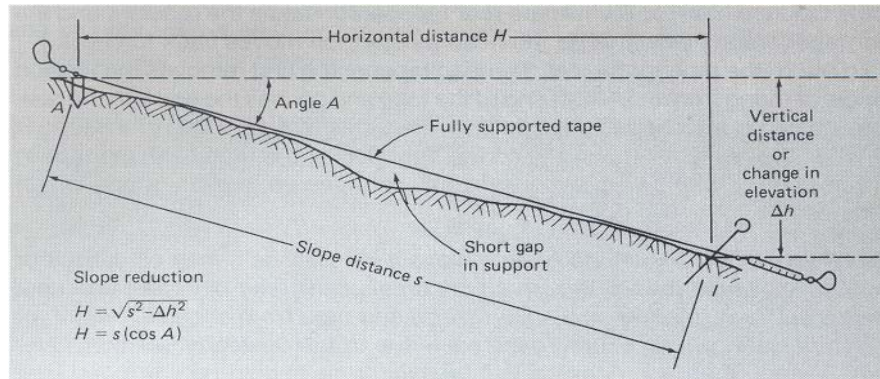

**Fig. 3.1.** Slope taping: the tape is fully supported on the ground. The effects of short gaps, as shown, are negligible.

By using combinations of these basic measurements it is possible to compute relative positions between any points.

Measurement of distances and angles is the essence of surveying.

Angle: it is simply figure formed by the intersection of two lines or figures generated by the rotation of a line about a point from an initial position to a terminal position. The point of rotation is called *the vertex of the angle*.

There are several systems of angle measurement. The most common ones are sexagesimal system and centesimal system

This system uses degrees, minutes and seconds. In this system, a complete rotation of a line (circle) is divided in to 360 degrees of arc. One degree is divided in to 60 minutes and 1 minute is further divided in to 60 seconds of arc. The symbols for degree, minutes and seconds are  $^{\circ}$ , ' and '' respectively.

E.g.  $35^{\circ} 17' 46''$   
 $90^{\circ}, 00' 00''$

One can perform additions, subtractions and conversions in the sexagesimal system as follows:

$$\begin{array}{r}
 + 35^{\circ} 17' 46'' \\
 \hline
 25^{\circ} 47' 36'' \\
 60^{\circ} 64' 82'' = 61^{\circ} 05' 22''
 \end{array}
 \qquad
 \begin{array}{r}
 - 90^{\circ} 00' 00'' \\
 \hline
 35^{\circ} 17' 46'' \\
 54^{\circ} 42' 14''
 \end{array}$$

Conversion  $35^{\circ} 30' = 35.50$   
 $142.125^{\circ} = 142^{\circ} 07' 30''$

## **B. The Centesimal System**

This system uses the grad for angular measurement. Here, a complete rotation is divided into 400 grads. The grad is subdivided into 100 parts called centigrad and the centigrad is further subdivided into 100 centi-centigrad ( $1^c = 100^{cc}$ )

For conversion  $1^g = 0.9^o$

Example. 100 grad = 90 degrees

## **3.4. SIGNIFICANT FIGURES**

A measured distance or angle is never exact; the 'true' or actual value can not be determined primarily because there is no perfect measuring instrument. The closeness of the observed value to the true value depends up on the quality of the measuring instrument and the care taken by the surveyor.

The number of significant figures in a measured quantity is the number of sure or certain digits, plus one estimated digit. This is a function primarily of the least count or graduation of the measuring instrument.

For example, an observed distance of 75.2 ft has three significant figures. It would be incorrect to report the distance as 75.200 ft (five significant digits), since that would imply a greater degree of exactness than can be obtained with the measuring instrument.

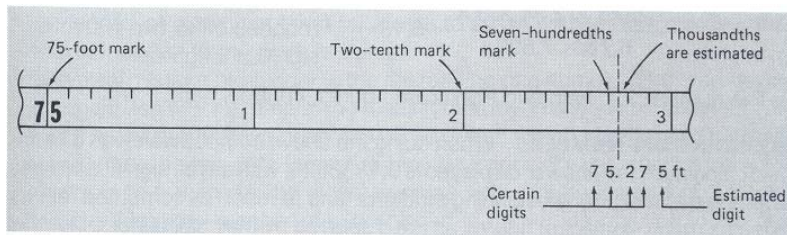

**Fig. 3.2.** Since the smallest interval on the steel tape is hundredth of a foot, a thousandth of a foot (the third decimal place) must be an estimated digit.

**3.4.1 Rules:** In general, zeros placed at the end of a decimal number are counted as significant. Zeros between other significant digits are also counted as significant. But zeros just to the right of the decimal, in numbers smaller than unity (1), are not significant. Also, trailing zeros to the right of the digits in a number written with out a decimal are generally not significant.

- Example,
- 75.200 ----- Five significant digits
  - 25.35 ----- Four significant digits
  - 0.002535 ----- Four significant digits
  - 12034 ----- Five significant digits
  - 120.00 ----- five significant digits
  - 12000. ----- Five significant digits.

The decimal would indicate that the number has five significant digits.



But in this case, it would be preferable to use scientific notation, that is,  $1.2 \times 10^4$ , to indicate the significance of the trailing zeros.

When numbers representing measured quantities are added, the sum cannot be any more exact than any of the original numbers. The least numbers of decimals is generally the controlling factor.

E.g.,  $4.52 + 23.4 + 468.321 = 496.241$  rounded off to  
496.2

When subtracting one number from another, it is best first to round off to the same decimal place.

E.g., 123.4 minus 2.345 may be computed as  
 $123.4 - 2.3 = 121.1$

The rule for multiplication (or division) is that the product (or quotient) should not have more significant figures than the numbers with the least amount of significant figures used in the problem.

E.g.  $\frac{1.2345 * 2.34 * 3.4}{6.78 * 7.890} = 0.18$  – rounded to two  
significant figures.

The number 3.4, with two significant figures, controls here.

### 3.4.2 Rounding Off Numbers

Use of too many significant figures is usually a sign that the surveyor or technician is inexperienced and does not fully understand the nature of the measurement or of the computation being performed.

In order to round off 0.1836028 to two significant figures, we simply dropped the extra digits after the 0.18. In general, if the first extra digit is less than five, we drop it along with any additional digits to the right. However, if the first digit is 5 or more, after we drop it, we must add 1 to the last digit of the number.

E.g., 3456 -----3500 rounded to two significant digits  
0.123 -----0.12 rounded to two significant digits  
4567 -----4570 rounded to three significant digits  
234.565 ---- 234.6 rounded to four significant digits

### 3.5. MISTAKES AND ERRORS

No measurement can be perfect or exact because of the physical limitations of the measuring instrument as well as limits in human perception. The difference between a measured distance or angle and its true value may be due to mistakes and /or errors. These are two distinct terms. It is necessary to *eliminate all mistakes* and to *minimize all errors* when conducting a survey of any type.

- ❖ **BLUNDERS:** A blunder is a significant mistake caused by human errors. It may also be called a *gross error*. Generally, it is due to the inattention or carelessness of the surveyor and it usually results in a large difference between the observed or recorded quantity and the actual or the true value.

Mistakes may be caused by sighting on a wrong target with the transit when measuring an angle, a by tapping to an incorrect station. They also may be caused by omitting a vital piece of information, such as the fact that a certain measurement was made on a steep slope instead of horizontally.

The possibilities for mistakes are almost endless. However, they are only caused by occasional lapses of attention.

- ❖ **ERRORS:** An error is the difference between a measured quantity and its true value, caused by imperfection in the measuring instrument, by the method of measurement, by natural factors such as temperature, or by random variation in human observation. It is not a mistake due to carelessness. Errors can never be completely eliminated, but they can be minimized by using certain instruments and field procedures and by applying computed correction factors.

### 3.5.1 Types of errors

There are two types of errors: Systematic errors and Accidental errors.

#### A. Systematic Errors

These are repetitive errors that are caused by imperfections in the surveying equipment, by the specific method of observation, or by certain environmental errors or cumulative errors.

Under the same conditions of measurement, systematic errors are constant in magnitude and direction or sign (either plus or minus). They usually have no tendency to cancel if corrections are not made.

For example, suppose that a 30-m steel tape is the correct length at 20<sup>o</sup>c and that it is used in a survey when the outdoor air temperature is, say 35<sup>o</sup>c. Since steel expands with increase in temperatures, the tape will actually be longer than it was at 20<sup>o</sup>c. And also transits, theodolites and even EDM are also subjected to systematic errors. The horizontal axis of rotation of the transit, for instance, may not be exactly perpendicular to the vertical axis.

#### B. Accidental Errors

An accidental or random error is the difference between a true quantity and a measurement of that quantity that is free from blunders or systematic errors. Accidental errors always occur

in every measurement. They are the relatively small, unavoidable errors in observation that are generally beyond the control of the surveyor. These random errors, as the name implies, are not constant in magnitude or direction.

One example of a source of accidental errors is the slight motion of a plumb bob string, which occurs when using a tape to measure a distance. The tape is generally held above the ground, and the plumb bob is used to transfer the measurement from the ground to the tape.

### **Most Probable Value**

If two or more measurements of the same quantity are made, random errors usually cause different values to be obtained. As long as each measurement is equally reliable, the average value of the different measurements is taken to be the true or the most probable value. The average (the arithmetic mean) is computed simply by summing all the individual measurements and then dividing the sum by the number of measurements.

### **THE 90 PERCENT ERRORS**

Using appropriate statistical formulas, it is possible to test and determine the probability of different ranges of random errors occurring for a variety of surveying instruments and procedures. The most probable error is that which has an equal chance (50 percent) of either being exceeded or not being exceeded in a particular measurement. It is sometimes designated as  $E_{90}$ .

In surveying, the 90 percent error is a useful criterion for rating surveying methods. For example, suppose a distance of 100.00 ft is measured. If it is said that the 90 percent error in one taping operation, using a 100 ft tape, is  $\pm 0.01$  ft, it means that the likelihood is 90 percent that the actual distance is within the range of  $100.00 \pm 0.01$  ft. Likewise, there will remain a 10 percent chance that the error will exceed 0.01 ft. It is sometimes called *maximum anticipated errors*.

The 90 percent error can be estimated from surveying data, using the following formula from statistics:

$$E_{90} = 1.645 \times \sqrt{[\sum(\Delta)^2/(n(n-1))]}$$

Where:  $\Sigma$  = sigma, "the sum of"

$\Delta$  = Delta, the difference between each individual measurement and the average of n measurements.

n = the number of measurements.

### 3.5.2 How Accidental Errors Add up

To measure the distance, we have to use the tape several times; there would be nine separate measurements for 900ft distance, each with a maximum probable error of  $\pm 0.01$  ft. It is tempting simply to say that the total error will be  $9 \times (\pm 0.01) = \pm 0.09$  ft. But this would be incorrect. Since some of the errors would be plus or some would be minus, they would tend to cancel each other out. Of course, it would be

very unlikely that errors would completely cancel, and so there still be a remaining error at 900 ft.

A fundamental property of accidental or random errors is that they tend to accumulate, or add up, in proportion to the square root of the number of measurements in which they occur. This relationship, called the law of compensation, can be expressed mathematically in the following equations:

$$E = E_1 \times \sqrt{n}$$

Where E = the total error in n measurements.

$E_1$  = the error for one measurement.

n = the number of measurements.

From the above example,  $E = \pm 0.01\sqrt{9} = \pm 0.01 \times 3 = \pm 0.03$  ft.

In other word, we can expect the total accidental error when measuring a distance of 900 ft to be within a range of  $\pm 0.030$  ft, with a confidence of 90 percent.

It must be kept in mind that this type of analysis assumes that the series of measurements are made with the same instruments and procedures as for the single measurement for which the maximum probable error is known.

### 3.5.3 Overview of Mistakes and Errors

1. Blunders can, and must, be eliminated.
2. Systematic errors may accumulate to cause very large errors in the final results.

3. Accidental errors are always present, and they control the quality of the survey.
4. Accidental errors of the same kind accumulate in proportion to the square root of the number of observations in which they are found.

### **3.6. Accuracy and Precision**

Accuracy and precision are two distinctly different terms, which are of importance in surveying. Surveying measurements must be made with an appropriate degree of precision in order to provide a suitable level of accuracy for the problem at hand.

Since no measurement is perfect, the quality of result obtained must be characterized by some numerical standard of accuracy.

*Accuracy* refers to the degree of perfection obtained in the measurement or how close the measurement is to the true value. When the accuracy of a survey is to be improved or increased, we say that greater precision must be used.

*Precision* refers to the degree of perfection used in the instruments, methods, and observations- in other word, to the level of refinement and care of the survey. In summary:

Precision – Degree of perfection used in the survey.

Accuracy – Degree of perfection obtained in the results.



In a series of independent measurements of the same quantity, the closer each measurement is to the average value, the better is the precision. High precision is costly but is generally necessary for high accuracy. The essential art of surveying is the ability to obtain the data required, with a specific degree of accuracy, at the lowest cost. The specified degree of accuracy depends on the type and the purpose of the survey.

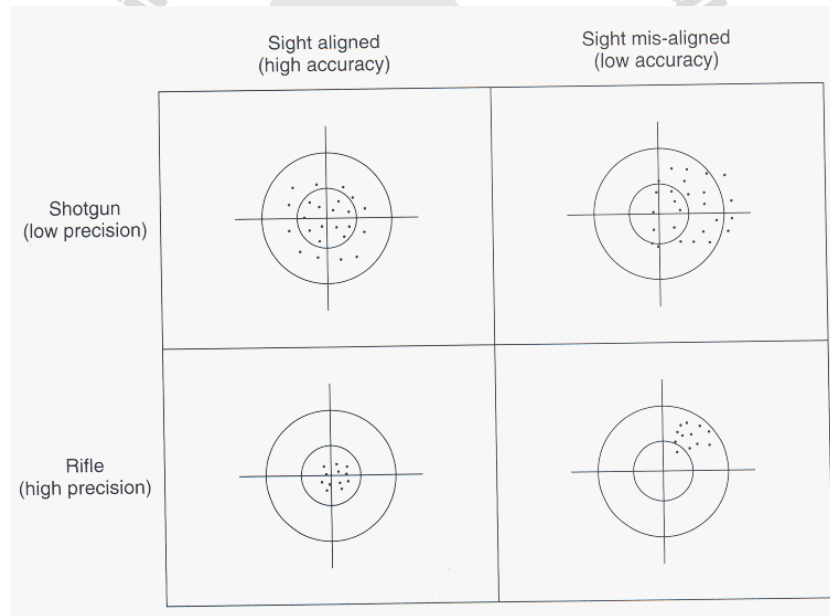

Fig. 3.3. *Illustration of accuracy and precision*

In the following example, the more precise method (steel tape) resulted in the more accurate measurement.

	“True” distance	Measured distance	Error
Cloth tape	157.22	157.2	0.02
Steel tape	157.22	157.23	0.01

However, it is conceivable that more precise method can result in less accurate answers. But if the steel tape had previously been broken and in correctly repaired, the result would still be relatively precise but very inaccurate.

### **Error Of Closure**

The difference between a measured quantity and its true value is called *error of closure*. In some cases, the closure can be taken simply as the difference between two independent measurements.

For example, suppose a distance from point A to point B is first determined to be 123.25 m. The line is measured a second time, perhaps from B to A, using the same instrument and methods. A distance of 123.19 m is obtained. The error of closure is simply  $123.25 - 123.19 = 0.06\text{m}$ . It is due to accidental errors, as long as blunders have been eliminated and systematic errors corrected.

## Relative Accuracy

For horizontal distances, the ratio of the error of closure to the actual distance is called the relative accuracy. Relative accuracy is generally expressed as a ratio with unity as the first number of numerator. For example, if a distance of 500 ft were measured with a closure of 0.25 ft, we can say that the relative accuracy of that particular survey is 0.25/500, or 1/2000. This is also written as 1:2000. This means basically that for every 2000 ft measured, there is an error of 1 ft. The relative accuracy of a survey can be compared with a specified allowable standard of accuracy in order to determine whether the results of the survey are acceptable.

Relative accuracy can be computed from the following formula:

$$\text{Relative accuracy} = 1: D/C$$

Where D = distance measured.

C = error of closure.

Selected US Standards for Traverse Survey

<b>Order</b>	<b>Relative Accuracy</b>	<b>Application</b>
First	1:100 000	Primary control nets; Precise scientific studies.
Second Class I Class II	1:50 000 1:20 000	Support for primary control; Control for large scale engineering projects
Third Class I Class II	1:10 000 1:5000	Small-scale engineering Projects; large-scale mapping projects

## Exercise

1. Define the term blunder and error.
2. Write the difference between blunder and error.
3. What are the basic difference between systematic error and an accidental error?
4. Indicate the type of error or mistake- the following would cause as A (Accidental), S (Systematic) or B (Blunder):
  - a. Swinging plumb bob while taping
  - b. Using a repaired tape
  - c. Aiming the theodolite at the wrong point
  - d. Recopying field data
  - e. Reading a 9 to a 6
  - f. Surveying with a level that is not leveled
  - g. Having too long a sight distance between the level and the level rod
5. Convert the following angles to decimal degree form:
  - a.  $35^{\circ}20'$ (use two decimal places)
  - b.  $129^{\circ}35'15''$ (use four decimal places)
6. Convert the following angles to degree, minutes, and seconds:
  - a.  $45.75^{\circ}$ (to the nearest minute)
  - b.  $123.1234^{\circ}$ (to the nearest second)
7. What is the sum of  $45^{\circ}35'45''$  and  $65^{\circ}50'22''$ ? Subtract  $45^{\circ}52'35''$  from  $107^{\circ}32'00''$ .

8. Convert the following angles to the sexagesimal system:
- a.  $75^{\circ}$       b.  $125.75^{\circ}$       c.  $200.4575^{\circ}$
9. How many significant digits are in the following numbers?
- a. 0.00123      b. 1.00468      c. 245.00  
d. 24500      e. 10.01      f. 45.6  
g. 1200      h. 1200•      i. 54.0  
j. 0.0987
10. Round off the sum of 105.4, 43.67, 0.975, and 34.55 to the appropriate number of decimal places.
11. Express the product of  $1.4685 \times 3.58$  to the proper number of significant figures.
12. Express the quotient of  $34.67 \div 0.054$  to the proper significant figures.
13. Round off the following numbers to three significant figures: 45.036, 245 501, 0.12345, 251.49, 34.009.
14. A distance was taped six times with the following results: 85.87, 86.03, 85.80, 85.95, 86.06, and 85.90 m. Compute the 90 percent error of the survey.
15. With reference to the above problem, what would the maximum anticipated error be for a survey that was three times as long, if the same precision was used?
16. A group of surveying students measure a distance twice, obtaining 67.455 and 67.350 m. What is the relative accuracy of the measurements?

17. Determine the accuracy of the following, and name the order of accuracy with reference to the US standards summarized.

Error, m	Distance, m
8.0	30560
0.07	2000
1.32	8460
0.13	1709
1.0	17543
0.72	1800

18. What is the maximum error of closure in a measurement of 2500 ft if the relative accuracy is 1:5000?

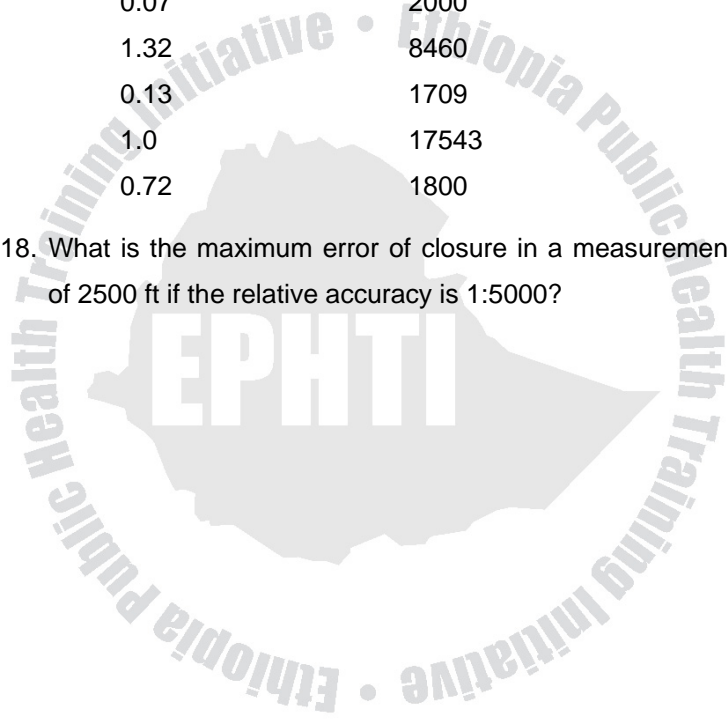

# CHAPTER FOUR

## MEASURING HORIZONTAL DISTANCES

### 4.1. Learning Objectives

At the end of this chapter, the student will be able to:

1. Measure horizontal distance
2. Identify and use different measurements
3. Identify equipments of horizontal measurement.
4. Identify the sources of errors and corrective actions.

### 4.2. Introduction

The tasks of determining the horizontal distances between two existing points and of setting a new point at a specified distance from some other fixed position are *fundamental surveying operations*. The surveyor must select the appropriate equipment and apply suitable field procedures in order to determine or set and mark distances with the required degree of accuracy.

Depending on the specific application and the required accuracy, one of several methods may be used to determine horizontal distance. The most common methods include pacing, stadia, taping, and EDM. Here, we will try to see the rough distance measurement by pacing and by using a measuring wheel. Stadia is an indirect method of



measurement that makes use of a transit, leveling and trigonometry.

Taping has been the traditional surveying method for horizontal distance measurement for many years. It is a direct and relatively slow procedure, which requires manual skill on the part of the surveyors.

### **4.3. Rough Distance Measurement**

In certain surveying applications, only a rough approximation of distance is necessary; a method called *pacing*, or the use of a simple measuring wheels, may be sufficient in these instances, e.g. locating topographic features during the preliminary reconnaissance of a building site, searching for the property corners etc. In this method, distances can be measured with an accuracy of about 1:100 by pacing. While providing only a crude measurement of distances, pacing has the significance advantage of requiring no equipment. It is a skill every surveyor should have. Pacing simply involves counting steps or paces while walking naturally along the line to be measured.

$$\text{Distance} = \text{Unit Pace} \times \text{Number of Paces}$$

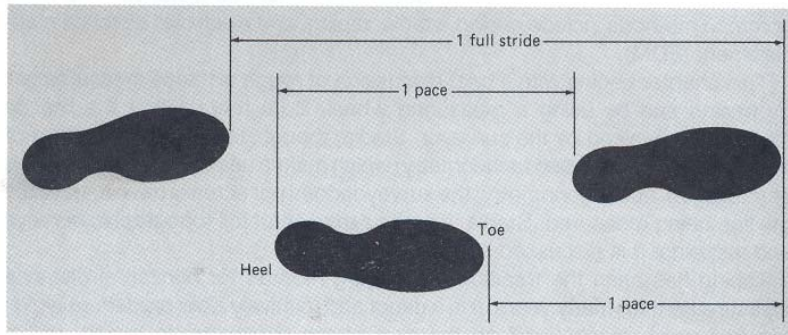

**Fig. 4.1.** Pacing provides a simple yet useful way to make distance measurement.

Depending on the skill and care applied, a pace distance can be determined with a relative accuracy of between 1:50 and 1:200.

**Class work:**

A surveyor student walked along a given line that was known to be 200.0 ft long, in order to determine her average unit pace. She paced the line five times, recording 78, 76.5, 77, 87, and 76 paces, respectively, in her field book.

- a. Determine her average unit pace.
- b. Compute the 90 percent error from the given data, and determine the relative accuracy of her pacing method.
- c. If the surveyor then counted an average of 123.5 paces while pacing off the line of unknown distance, what is the distance?

#### USING THE MEASURING WHEEL

A simple measuring wheel mounted on a rod can be used to determine distances, by pushing the rod and rolling the wheel along the line to be measured. An attached device called an *odometer* serves to count the number of turns of the wheels. From the known circumference of the wheel and the number of revolutions, distances for reconnaissance can be determined with relative accuracy of about 1:200. This device is particularly useful for rough measurement of distance along curved lines.

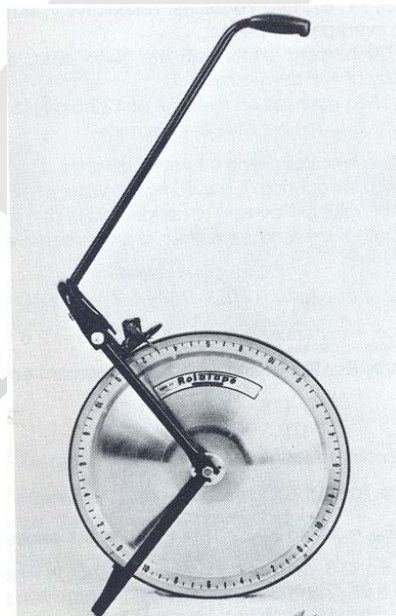

**Fig. 4.2.** A typical measuring wheel used for making rough distance measurements.

$$\text{Distance} = \text{Odometer Reading} \times \text{Circumference of the Wheel (IDD)}$$

Where  $D$  is the diameter of the measuring wheel

#### 4.4. Taping Equipments and Methods

Measuring horizontal distances with a tape is simple in theory, but in actual practice, it is not as easy as it appears at first glance. It takes skill and experience for a surveyor to be able to tape a distance with a relative accuracy between 1:3000 and 1:5000, which is generally acceptable range for most preliminary surveys.

##### 4.4.1. Tapes and Accessories

Most of the original surveys were done using *Gunter's chain* for measurement of horizontal distances. To this day, the term *chaining* is frequently used to describe the taping operation. While the Gunter's chain itself is no longer actually used, steel tapes graduated in units of chains and links are still available.

##### Steel Tapes

Modern steel tapes are available in variety of lengths and cross sections; among the most commonly used are the 100ft-tape and the 30-m tape, which are  $\frac{1}{4}$  in and 6 mm wide, respectively. Both lighter as well as heavier duty tapes are also available.

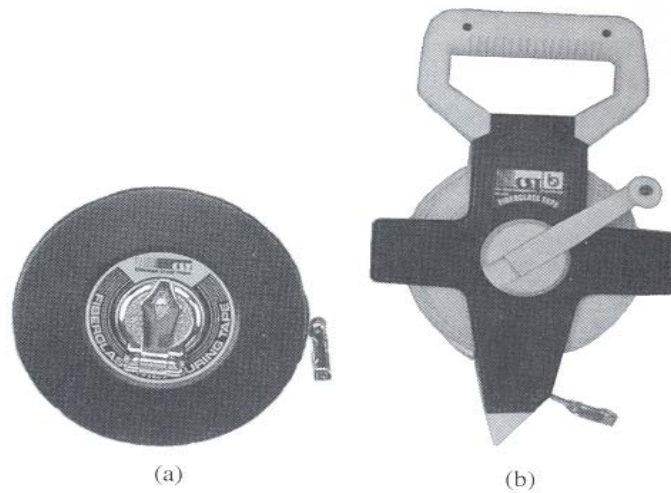

**Fig. 4.3.** Fiberglass tapes (a) Closed case; (b) Open reel

#### **4.4.2. Accessories for Taping**

Accurate taping cannot be done with the tape alone. When taping horizontal distances, the tape very often must be held above the ground at one or both ends. One of the most important accessories for proper horizontal taping is the *plumb bob*. It is a small metal weight with a sharp, replaceable point. Freely suspended from a chord, the plumb bob is used to project the horizontal position of a point on the ground up to the tape, or vice versa.



**Fig. 4.4.** A plumb bob: (is one of the simplest yet most important accessories for accurate surveying.)

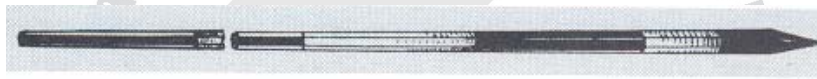

**Fig. 4.5.** A surveyor's range pole.

When a transit or theodolite is not used to establish direction, range pole serve to establish a line of sight and keep the surveyors properly aligned. A range pole would be placed vertically in the ground behind each endpoint of the line to be measured.

Steel taping pins are used for marking the end of the tape, or intermediate points, when taping over grass or unpaved ground. Taping pins are most useful for tallying full tape lengths over long measured distances.

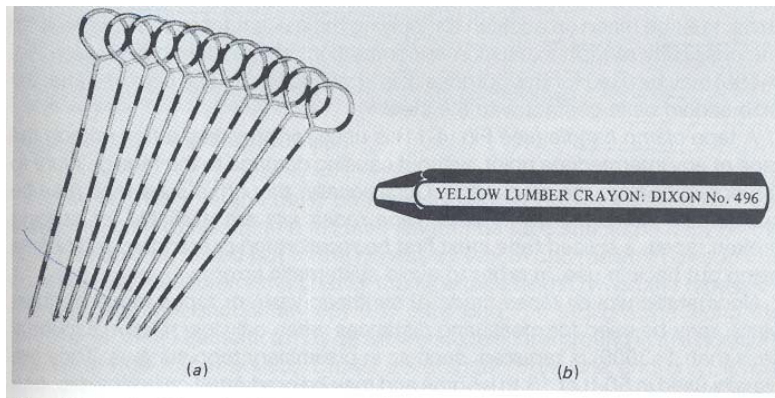

**Fig. 4.6.** (a) Chaining pin (b) Keel

When taping horizontal distances, it is necessary to hold the tape as close to a horizontal position as possible. In order to reduce errors caused by an excessively sloped tape, some surveyors make use of a *hand level*. A horizontal line of sight can be easily obtained by looking through the level towards the surveyor at the higher end of the tape.



**Fig. 4.7.** Hand level

When ever possible, a spring-balance tension handle should be attached to the forward end of the tape to indicate whether or not the correct pull or tension is applied. Applying the correct tension is particularly important if a relative accuracy of better than 1:3000 is required.

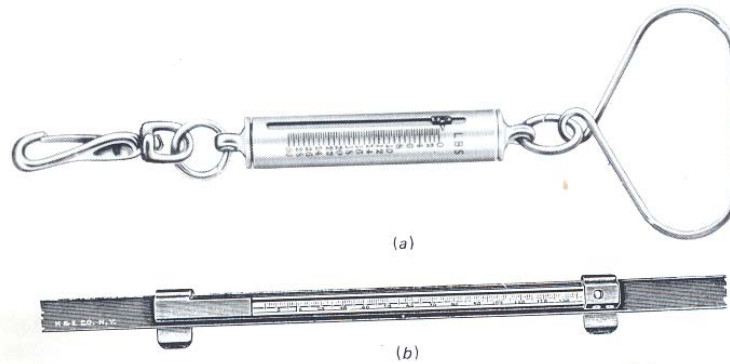
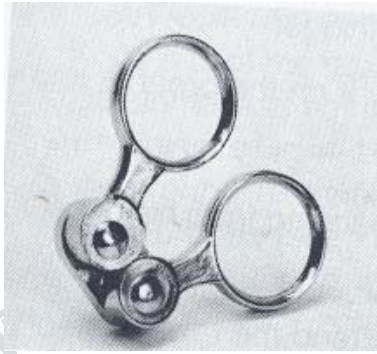

**Fig 4.8** (a) Spring Balance (b) Tape thermometer

For precise taping with accuracies better than 1:5000, temperature correction must be made to account for the possibility of tape expansion or contraction; *tape thermometer* may be used for this purpose. It is attached to the tape near one end; the bulb should be in contact with the steel.

A *tape clamp handle* is used for providing a firm grip on the tape at any intermediate point, with out causing damage to the tape or injury to the surveyor from the steel edge.





**Fig. 4.9.** A tape clamp handle.

#### **4.4.3. Taping Horizontal Distances**

Taping may be used to determine the unknown distances between two fixed points on the ground, or it may be used to set marks at specified distances on the given line. This operation is called *setting marks for line and distance*. Setting marks for line and distance typically involves the use of theodolite to establish the proper direction of the line and to help keep the marks set by the tape person exactly on that direction.

Clearly, at least two surveyors are needed to tape a distance—a front, or head, tape person to hold the front end of the tape and a rear tape person to hold the back of the tape. It is best, for taping to be performed with a three-person crew; the third member of the group provides valuable assistance in assuring proper tension and alignment of the tape, setting the chaining pins, double checking tape readings.

When a series of marks are set on a line at measured distances, surveyor uses a standard system of identifying the marks; the marks are called *stations*. The stations may be very temporary or somewhat long lasting. Stationing is particularly important when doing profile leveling, as well as when setting marks for line and distance in route survey.

#### 4.4.4. Horizontal Measurement on Sloping

##### Ground and slop measurements

In taping on uneven or sloping ground, it is standard practice to hold the tape horizontal and use a plumb bob at one or both ends. It is difficult to keep the plumb line steady for height above the chest. Wind exaggerates the problem and may make accurate work impossible.

When a 100 m length cannot be held horizontally with out plumbing from above shoulder level, shorter distances are measured and accumulated to total a full tape length. This procedure, called *breaking tape*.

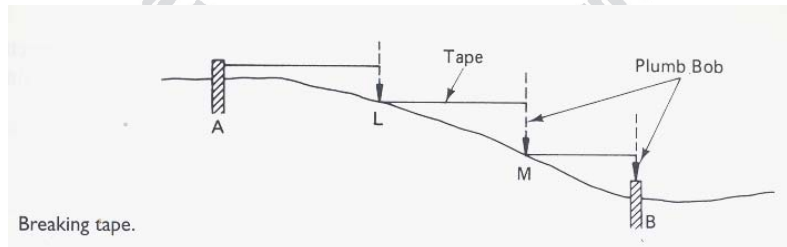

**Fig. 4.10.** Breaking tape.

In measuring the distance between two points on a steep slope, rather than break tape every few meters, it may be desirable to tape along the slope and compute the horizontal component. This requires measurement also of either the angle of inclination **A** or the difference in elevation  $\Delta h$ . Breaking tape is more time consuming and generally less accurate due to the accumulation of random errors from making tape ends and keeping the tape level and aligned for many short sections.

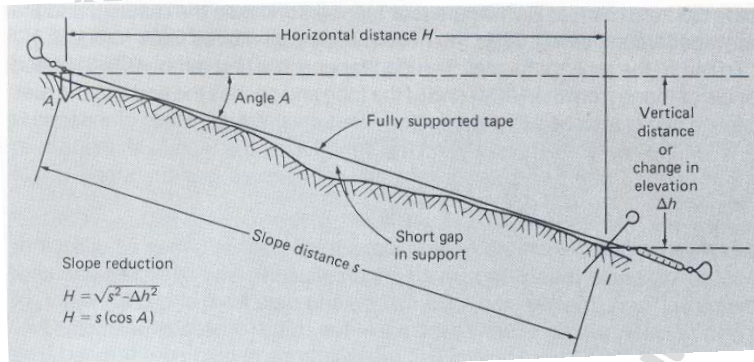

**Fig.4.11.** Slope taping: (the tape is fully supported on the ground. The effects of short gaps, as shown, are negligible.)

If angle **A** is determined, the horizontal distance between point A and B can be computed from the relation:

$$\boxed{H = S \cos A}$$

Where: H: is the horizontal distance between points  
 S: the slope length separating the two points.  
 A: The vertical angle from the horizontal.

If the difference in elevation 'd' between the ends of the tape is measured, which is done by leveling, the horizontal distance can be computed using the following expression

$$H = \sqrt{(s^2 - \Delta h^2)}$$

Another approximate formula may be used to reduce slope distance to horizontal.

$$H = S - \Delta h^2 / 2S$$

#### 4.4.5. Identifying Stations

A zero position is usually established at the beginning of the survey or at the beginning of the line to be marked out. This zero point is identified as 0+00. Each point located at the intervals of exactly 100 m from the beginning point is called a *full station* and is identified as follows: a point 100 m from 0+00 is labeled station 1+00, a point 200 m from the zero point is station 2+00, and so on.

Points located between the full stations are identified as follows: a point 350 m from the zero point is called 3+50, and a point 475 m from zero is called 4+75. At a distance of 462.78 m from the zero, the station called 4+62.78. The +50, +75, +62.78 are called *pluses*.

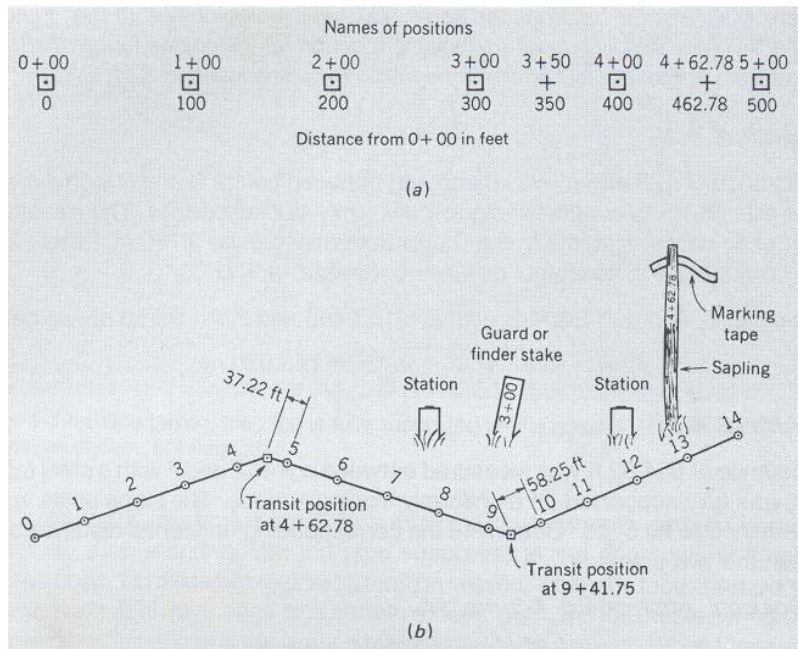

**Fig. 4.12.** The positions along a measured line are called stations.

#### 4.4.6. Taping Mistakes and Errors

As in any kind of surveying operation, taping blunders must be eliminated, and taping errors, both random and systematic, must be minimized to achieve accurate results.

*Example of TAPING MISTAKES AND BLUNDERS:*

- Misreading the tape, particularly reading a 6 for a 9.
- Misrecording the reading, particularly by transposing digits.

- Mistaking the end point of the tape.
- Miscounting full tape length, particularly when long distances are taped.
- Mistaking station markers.

### **Sources of Errors in Taping**

There are three fundamental sources of errors in taping.

1. *Instrumental errors*: A tape may differ in actual length from its nominal graduation and length because of defects in manufacturing or repair.
2. *Nominal errors*: The horizontal distance between end graduations of a tape varies because of the effects of temperature, wind and weight of the tape itself.
3. *Personal errors*: Tape persons may be careless in setting pins, reading tapes, or manipulating the equipment.

### **❖ Systematic Errors in Taping**

Systematic errors in taping linear distances are those attributable to the following causes

- The tape is not of standard length
- The tape is not horizontal
- Variation in temperature
- Variation in tension
- Sag
- Incorrect alignment of tape
- The tape is not straight

#### 4.4.7. Corrections

##### 1. Incorrect Length of Tape

Incorrect length of a tape can be one of the most important errors. It is systematic.

For example, a 100 m steel tape usually is standardized under set of condition- 68<sup>0</sup>F and 12 lb pull.

An error due to incorrect length of a tape occurs each time the tape is used. If the true length, known by standardization, is not exactly equal to its nominal value of 100.00 m recorded for every full length, the correction can be determined and applied from the formulas:

$$C_l = \left( \frac{l - l'}{l'} \right) L$$

$$\bar{L} = L + C_l$$

Where:  $C_l$ : is the correction to be applied to the measured length of a line to obtain the true length

$l$ : the actual tape length

$l'$ : the nominal tape length

$L$ : the measured length of the line

$\bar{L}$ : The corrected length of the line.

Sometimes, the changes in length are quite small and of little importance in many types of surveys. However, when good relative accuracy is required, the actual tape length must be known within 0.005 ft (1.5 mm). The actual length of a working tape, then, must be compared with a standard tape

periodically. When its actual length is known, the tape is said to be standardized. A correction must be added or subtracted to a measured distance whenever its standardized length differs from its nominal or graduated length.

**N.B:** *In measuring unknown distances with a tape that is too long, a correction must be added. Conversely, if the tape is too short, the correction will be minus, resulting in decrease.*

## 2. Temperature Other Than Standards

Steel tapes are standardized for 68°F or 20°C. A temperature higher than or lower than this value causes a change in length that must be considered. The coefficient of thermal expansion and contraction of steel used in ordinary tapes is approximately  $1.16 \times 10^{-5}$  per length per °C. For any tapes the correction for temperature can be computed and applied using the formula

$$C_t = K (T_1 - T) L$$

$$\bar{L} = L + C_t$$

Where:  $C_t$ : is the correction in length of a line due to nonstandard temperature.

K: the coefficient of thermal expansion and correction of the tape.

$T_1$ : the tape temperature at the time of measurement.

T: the tape temperature when it has standard length.

L: the measured length of the line.

$\bar{L}$ : The corrected length of the line.



### 3. Inconsistent Pull

When a steel tape is pulled with a tension greater than its standard, the tape will stretch and be no longer than its standard length. Conversely, if less than standard pull is used, the tape will be shorter than its standard length. The modulus of elasticity of the tape regulates the amount that it stretches. Correction pull can be computed and applied using the following formulas:

$$C_p = (P_1 - P) \frac{L}{AE}$$

$$\bar{L} = L + C_p$$

Where:  $C_p$ : is the total elongation in tape length due to the pull, in meter.

$P_1$ : the pull applied to the tape, in Kg.

$P$ : the standard pull for the tape, in Kg.

$A$ : tape's cross sectional area of the tape.

$E$ : the modulus of elasticity of the steel.

$L$ : the measured length of the line, meter.

$\bar{L}$ : The correct length.

### 4. SAG

A steel tape not supported along its entire length sags in the form of a *catenary's*, may results. Sag shortens the horizontal distance between end graduations, because the tape length remains the same. Sag can be diminished but not eliminated unless the tape is supported throughout.

The following formulas are used to compute the sag correction:

$$C_s = \frac{w^2 L_s^3}{24P_1^2}$$

OR

$$C_s = \frac{W^2 L_s}{24P_1^2}$$

Where  $C_s$ : is the correction for sag, in meter.

$L_s$ : the unsupported length of the tape, in meter.

$w$ : weight of the tape per meter of length.

$W$ : total weight of the tape between the supports, Kg.

$P_1$ : is the pull on the tape, in Kg.

In measuring lines of unknown length, the sag correction is always negative. After a line has been measured in several segments, and a sag correction has been calculated for each segment, the corrected length is given by

$$\bar{L} = L + \sum C_s$$

Where  $\bar{L}$ : is the corrected length of the line.

$L$ : the recorded length of the line

$\sum C_s$ : the sum of individual sag corrections.

##### 5. Normal Tension

By equating equations  $C_s = C_p$ ,

$$\frac{w^2 L_s^3}{24P_1^2} = \frac{(P_1 - P)L}{AE}$$

i.e. the elongation due to increase in tension is made equal to the shortening due to sag; thus, the effect of the sag can be eliminated. The pull that will produce this condition, called Normal Tension  $P_n$  is given by the formula.

$$P_n = \frac{0.204 W \sqrt{AE}}{\sqrt{P_n - P}}$$

Where:  $P_n$  = normal tension

$P$  = Standard pull for the tape, Kg

$W$  = Total weight of the tape between the support, Kg

$A$  = tape's cross sectional area

$E$  = Modulus of elasticity of steel

## Exercise

1. A student counted 188,186,187,188,186,187 paced in six trials of walking along a course of 500-ft known length on level ground. Then 211,212,210 and 212 paces were counted in walking four repetitions of an unknown distance AB. What is
  - a). The pace length
  - (b). The length of AB
2. For the following data, compute the horizontal distance for a recorded slope distance AB
  - (a). AB = 327.28 ft, slope angle =  $4^{\circ}15'$
  - (b). AB = 382.96 m, difference in elevation A to B = 18.3 m
  - (c). AB = 651.54 ft, grade = 4.5%
3. A 100-ft steel tape of cross-section area  $0.0030 \text{ in}^2$ , weight 1.0 lb, and standardized at  $68^{\circ}\text{F}$  is 100.016 ft between end marks when supported through out under a 12-lb pull. What is the true horizontal length of a recorded distance AB for the conditions given below? (Assume horizontal taping)

RECORDED DISTANCE AB (ft)	AVERAGE TEMPRATURE ( $^{\circ}\text{F}$ )	MEANS OF SUPPORT	TENSION (lb)
536.90	68	Throughout	12
629.54	102	Throughout	16
966.35	22	Ends only	18

4. For the tape in the above question, determine the true horizontal length of the recorded slope distance BC for the conditions given below. (Assume the tape was fully supported for all measurements)

RECORDED SLOPE DISTANCE BC	AVERAGE TEMPRATURE (°F)	TENSION (lb)	ELEVATION DIFFERENCE PER 100 ft (ft)
496.25	87	12	6.8
576.81	38	20	5.2

5. Determine the horizontal length of CD that must be laid out to achieve required true horizontal distance CD. assume a 100-ft steel tape will be used, with cross-sectional area 0.0060 in<sup>2</sup>, weight 2.0 lb, and standardized at 68 °F to be 100.014 ft between end marks when supported through out with a 12-lb pull.

REQUIRED HORIZONTAL DISTANCE CD (ft)	AVERAGE TEMPRATURE (°F)	MEANS OF SUPPORT	TENSION (lb)
200.00	68	Throughout	12
378.68	37	Ends only	16
97.00	46	Ends only	18

6. For the tape in Q.5, determine the slope length that must be laid out to achieve required true horizontal distance DE for the conditions below. (Assume the tape will be fully supported for all measurements)

REQUIRED HORIZONTAL DISTANCE DE (ft)	AVERAGE TEMPRATURE (°F)	TENSION (lb)	SLOPE
200.00	17	12	3.5ft/100ft
618.42	55	18	6% grade

7. In taping from A to B, a tree on-line necessitated setting an intermediate point C offset 4.5 ft to the side of the line AB. Line AC was then measured as 368.92 ft along uniform 4% slope. Line CB on horizontal ground was measured as 285.10 ft. Find the horizontal length of AB
8. A 100-ft steel tape having a cross-sectional area of 0.0048 in<sup>2</sup> is exactly 100.00 ft along at 68°F when fully supported under a pull of 12-lb. By trial and error, determine the normal tension for this tape.
9. A triangular piece of land is bounded by 42.5 m of fencing on one side, 51.2m of stonewall on another side, and 85.7 of road frontage on the third side. What are the interior angles formed by the boundary lines?
10. Two points on the opposite sides of a lake, D and E, are 355.5 and 276.2 ft, respectively, from the third point, F, on the shore. The lines joining points D and E with point F intersect at an angle of 71°45'. What is the distance DE?

# CHAPTER FIVE

## LEVELING

### 5.1. LEARNING OBJECTIVES

At the end of this chapter, the students will be able to:

1. Define and describe different types of leveling.
2. Understand the principles of leveling and measure vertical distances
3. Apply the skills of leveling
4. Identify measurement errors and take corrective actions.

### 5.2 Introduction

Leveling is the general term applied to any of the various processes by which elevations of points or differences in elevation are determined. It is a vital operation in producing necessary data for mapping, engineering design, and construction.

Leveling results are used to:

1. Design highways, railroads, canals, sewers etc.
2. Layout construction projects according to planned elevations.
3. Calculate volume of earthwork and other materials.
4. Investigate drainage characteristics of the area.
5. Develop maps showing ground configuration.

### **5.3. Measuring Vertical Distances**

The vertical direction is parallel to the direction of gravity; at any point, it is the direction of a freely suspended plumb-bob cord. The vertical distance of a point above or below a given reference surface is called *the elevation of the point*. The most commonly used reference surface for vertical distance is *mean sea level*. The vertical distances are measured by the surveyor in order to determine the elevation of points, in a process called *running levels or leveling*.

The determination and control of elevations constitute a fundamental operation in surveying and engineering projects. Leveling provides data for determining the shape of the ground and drawing topographic maps and the elevation of new facilities such as roads, structural foundations, and pipelines.

### **5.4. Methods OF Leveling**

There are several methods for measuring vertical distances and determining the elevations of points. Traditional methods include *barometric leveling*, *trigonometric leveling* and *differential leveling*. Two very advanced and sophisticated techniques include *inertia leveling* and *global positioning systems*.



## **1. Barometric leveling**

By using special barometers to measure air pressure (which decrease with increasing elevation), the elevation of points on the earth's surface can be determined within  $\pm 1\text{m}$ . This method is useful for doing a reconnaissance survey of large areas in rough country and for obtaining preliminary topographic data.

## **2. Differential leveling**

By far the most common leveling method, and the one which most surveyors are concerned with, is differential leveling. It may also be called *spirit leveling*, because the basic instrument used comprises a telescopic sight and a sensitive *spirit bubble vial*. The spirit bubble vial serves to align the telescopic sight in a horizontal direction, that is, perpendicular to the direction of gravity.

Briefly, a horizontal line of sight is first established with an instrument called a *level*. The level is securely mounted on a stand called a *tripod*, and the line of sight is made horizontal. Then the surveyor looks through the *telescopic sight* towards a *graduated level rod*, which is held vertically at a specific location or point on the ground. A reading is observed on the rod where it appears to be intercepted by the horizontal cross hair of the level; this is the vertical distance from the point on the ground up to the line of sight of the instrument.

Generally, if the elevation of point A is already known or assumed, then the rod reading on a point of known elevation is termed as a *back sight reading* (*plus sight*, because it must be added to the known elevation of point A to determine the elevation of the line of sight).

For example, suppose the elevation of point A is 100.00 m (above MSL), and the rod reading is 1.00m. It is clear that the elevation of the line of sight is  $100.00 + 1.00 = 101.00\text{m}$ . The elevation of the horizontal line of sight through the level is called the *height of instrument* (HI).

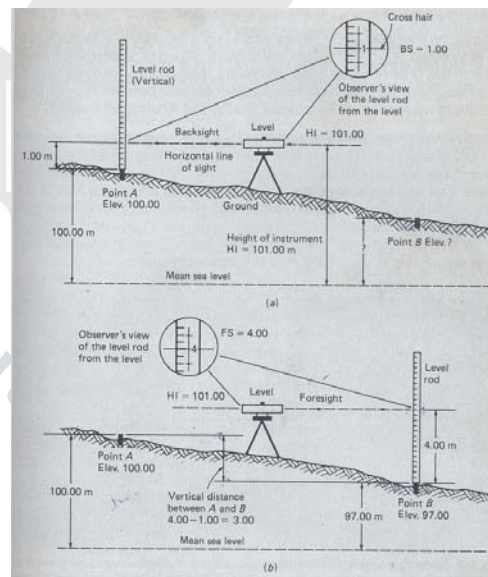

**Fig. 5.1.** Differential leveling to measure vertical distance and elevation. (a) Step 1: take a backsight rod reading on point A (b) Step 2: rotate the telescope toward point B and take foresight rod reading.

Suppose we must determine the elevation of point B. The instrument person turns the telescope so that it faces point B, and reads the rod now held vertically on that point. For example, the rod reading might be 4.00m. A rod reading on a point of unknown elevation is called *foresight (minus sight)*. Since the HI was not changed by turning the level, we can simply subtract the foresight reading of 4.00 from the HI of 101.00 to obtain the elevation of point B, resulting here in  $101.00 - 4.00 = 97.00\text{m}$ .

The operation of reading a vertical rod held alternately on two nearby points is the essence of differential leveling. The difference between the two rod readings is, in effect, the vertical distance between the two points.

The basic cycle of differential leveling can be summarized as follows:

$$\begin{aligned} \textit{Height of Instrument} &= \textit{Known elevation} + \textit{backsight} \\ \textit{HI} &= \textit{Elev}_A + \textit{BS} \end{aligned}$$

$$\begin{aligned} \textit{New elevation} &= \textit{height of instrument} - \textit{foresight} \\ \textit{Elev}_B &= \textit{HI} - \textit{FS} \end{aligned}$$

Frequently, the elevations of points over a relatively long distance must be determined. A process of measuring two or more widely separated points simply involves several cycles or repetitions of the basic differential leveling operation. More

specific terms for this are *benchmark*, *profile*, and *topographic leveling*.

## 5.5 Benchmarks and Turning Points

Suppose it is necessary to determine the elevation of some point C from point A. But in this case, let us assume that it is not possible to set up the level so that both points A and C are visible from one position. The line of levels can be carried forward towards C by establishing a convenient and temporary *turning point (TP)* somewhere between A and C. The selected TP serves merely as an intermediate reference point; it does not have to be actually set in the ground as a permanent monument.

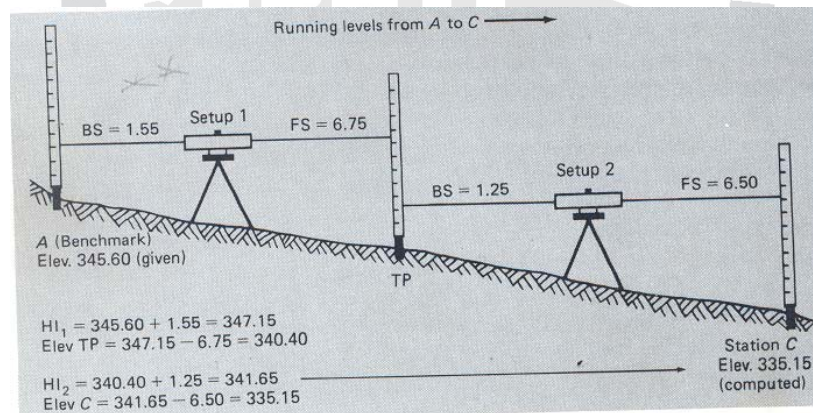

**Fig. 5.2.** Temporary turning points are used to carry a line of levels from a benchmark to some other station or benchmark; the process of differential leveling is repeated at each instrument set up.

The elevation of the turning point is computed from the first pair of BS and FS readings. The BS is on point A, which is the end point of known elevation. A secure and permanent point of known elevation is called a *bench mark* (BM); a leveling survey should begin with a back sight on a benchmark. The BS is added to the elevation to give the HI at the first instrument position.

The elevation of the turning point is obtained by subtracting the FS from the HI. Once the elevation of the turning point is known, the level instrument can be moved to another location, one closer to C but still in sight of the turning point. Then another back sight is taken, this time on the turning point, in order to determine the new height of instrument. Finally a foresight is taken on point C, and its elevation is computed.

**Table 5.1.** Field book format for leveling notes.

Record the given elevation of A.	Station	BS " "+"	HI	FS " _"	Elevation
Read BS on A; compute HI for first setup.	BM A	<sup>(2)</sup> 1.55	<sup>(3)</sup> 347.15		<sup>(1)</sup> 345.60
(Numbers in parentheses upper left indicate order of data entry.)					

(a)

Read FS ON TP; compute the elevation of TP.	Station	BS " "+"	HI	FS " _"	Elevation
Read BS on TP; compute HI for second setup.	BM A	1.55	347.15		345.60
	TP	<sup>(6)</sup> 1.25	<sup>(7)</sup> 341.65	<sup>(4)</sup> 6.75	<sup>(5)</sup> 340.40

(b)

Read FS on C; compute elevation of station C.	Station	BS " "+"	HI	FS " _"	Elevation
Sum BS and FS columns; add to elevation of A as a check on math.	BM A	1.55	347.15		345.60
	TP	1.25	341.65	6.75	340.40
	C			<sup>(8)</sup> 6.50	<sup>(9)</sup> 335.15
	<sup>(10)</sup> Sum =	+ 2.80		-13.25	

<sup>(11)</sup> Arithmetic check:  $345.60 + 2.80 - 13.25 = 335.15$

(c)

## 5.6 Inverted Staff Readings

In all of the previous topics on leveling, the points observed all lay below the line of sight. Frequently on building sites, the reduced levels of points above the height of the instrument are required, e.g. the soffit level of a bridge or under pass, the under side of a canopy, the level of roofs, eaves, etc. of buildings. Figure below illustrates a typical case.

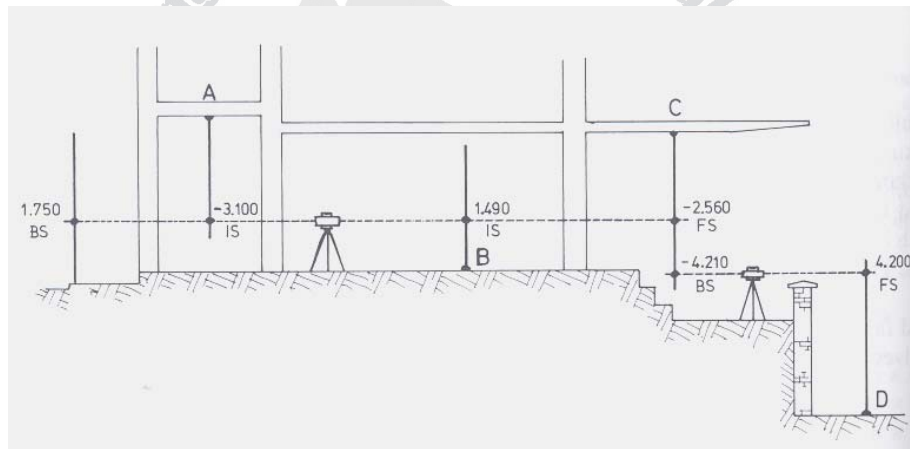

**Fig. 5.3.** Illustration of inverted staff reading.

The reduced levels of points A, B, C, and D on the frame of a multi-storey building require checking. The staff is simply held upside down on the points A and C and booked with a negative sign in front of the reading, e.g.  $-1.520$ . Such staff readings are called *Inverted Staff Readings*.



**Table 5.2.** Shows the readings observed to the points A, B, C, and D on the multistorey building of figure 5.3.

<i>BS</i>	<i>IS</i>	<i>FS</i>	<i>HPC</i>	<i>Reduced level</i>	<i>Remarks</i>
1.750	-3.100 1.490		74.050	72.300 77.150 72.560	Bench mark A. Frame liftshaft B. Floor level C. Canopy D. Kerb
-4.210		-2.560 4.200	72.400	76.610 68.200	
-2.460 -1.640 -4.100	-1.610	1.640		68.200 -72.300 -4.100	

### 5.7 Reciprocal leveling

When it is necessary to run levels accurately over rivers and other obstacles where the BS and FS distances must necessarily be different, a procedure called reciprocal leveling is used. This provides another way to cancel or average out instrumental errors as well as the effects refraction and the earth's curvature.

This procedure involves two instrument setups, one near by each point. From each instrumental position, BS on point A and an FS on point B are taken, and an elevation is computed for point B. This will result in to different elevations for B, due to the natural and instrumental errors. But by average the two elevations, the effects on the errors are cancelled out, and the 'true' or most probable elevation is obtained.



## 5.8 Leveling Equipment

There are several types of surveying levels and level rods. Some are meant primarily for precise leveling work, and others are much better suited for ordinary construction and operation of the various types of leveling equipments, so as to be able to select and use the best instrument for a particular surveying assignment.

Compared with a transit or theodolite, the level is a relatively simple instrument. It is only required to give a horizontal line of sight in all directions of the compass, and this is easily accomplished using basic optical and mechanical components.

A surveying level basically consists of a telescope and a sensitive spirit bubble vial. The spirit level vial can be adjusted so that, when the bubble is centered, the line of sight through the telescope is horizontal. The telescope is mounted on a vertical spindle, which fits into a bearing in the leveling head. The leveling head may have either three, or two leveling screws, depending on the type of instrument.

The most common types of levels are *the dumpy level*, *the tilting level* and *the automatic level*. A transit or theodolite may also be used for leveling work, although the accuracy obtained is generally less. A simple hand level may be used for determining the elevations when a high degree of accuracy is not required.

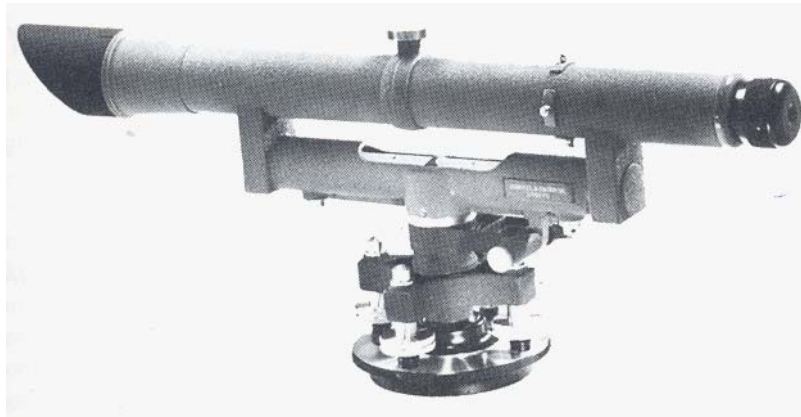

**Fig 5.4.** Dumpy level

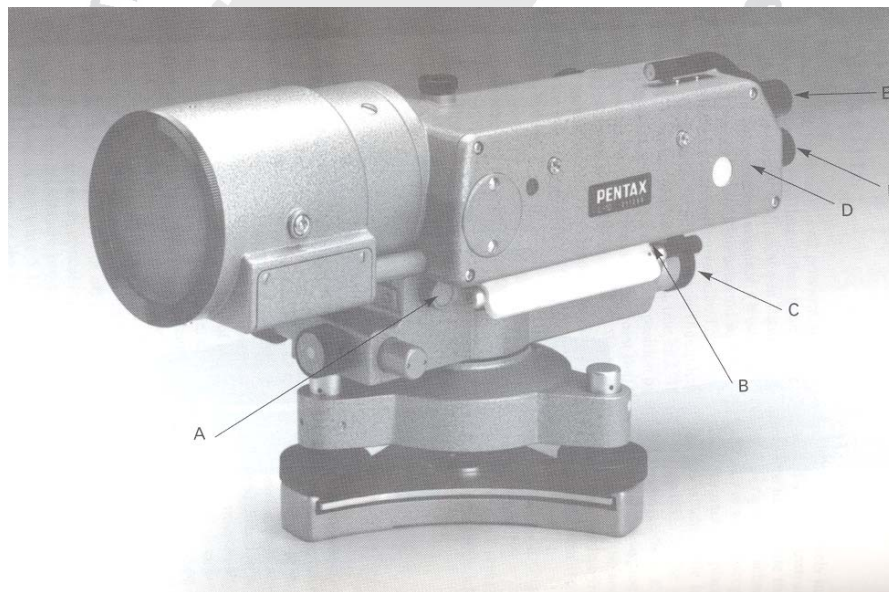

**Fig 5.5.** Tilting Level

- A: Transverse fulcrum
- B: Micrometer screw
- C: Micrometer screw knob
- D: Housing for telescope level bubble
- E: Eyepiece end of the telescope
- F: Parallel eyepiece



**Fig 5.6.** Automatic Levels

The most common components of several types of levels are the *telescopic sight and spirit bubble vial*.

#### **a. The Telescopic Sight**

The modern telescopic sight consists of the following components:

1. A reticle, which provides the *cross hair*, near the rear of the telescope tube.
2. A microscope or eyepiece which magnifies the cross hair, and which must be focused on them according to the eyesight of the observer.
3. An objective lens at the forward end of the telescope, which forms an image of the sight target within the telescope tube.
4. A focusing lens, which can be moved back and forth inside the scope to focus the image on the cross hair.

#### **Focusing a Telescoping sight:**

Three steps are required to focus a telescopic sight for greatest accuracy.

1. Aim the telescope at the bright, unmarked object, such as the sky, and regulate the eyepiece until the cross hair is in sharp focus.
2. Aim the telescope at the object to be viewed and, while keeping the eye focused on the cross hairs, regulate the focusing lens until the object is clear.
3. Eliminate parallex.

### **The Line Of Sight**

A straight line from any point on the image through the optical center of the objective lens will strike a corresponding point on the object. A straight line from the cross hairs through the optical center of the lens will strike the point on the object where the observer sees the cross hairs apparently located. Thus the *cross hairs and the optical center of the objective define the line of sight of a telescopic sight.*

### **b. The Spirit Bubble Tube Or Circle**

A spirit bubble vial consists of a glass container, which is partly filled with a clear, nonfreezing, very low viscosity liquid such as alcohol or ether.

#### **Level Rods**

There are many different types of level rods. Generally, the body of the rod is made of seasoned hardwood; this act as a rigid support for the rod face, a strip of steel graduated upward starting from zero at the bottom. The rod person, on a point of known elevation for a BS, or a point of unknown elevation, holds the rod vertically for an FS. The rod is then observed with the level and read by the instrument person on the target rod.

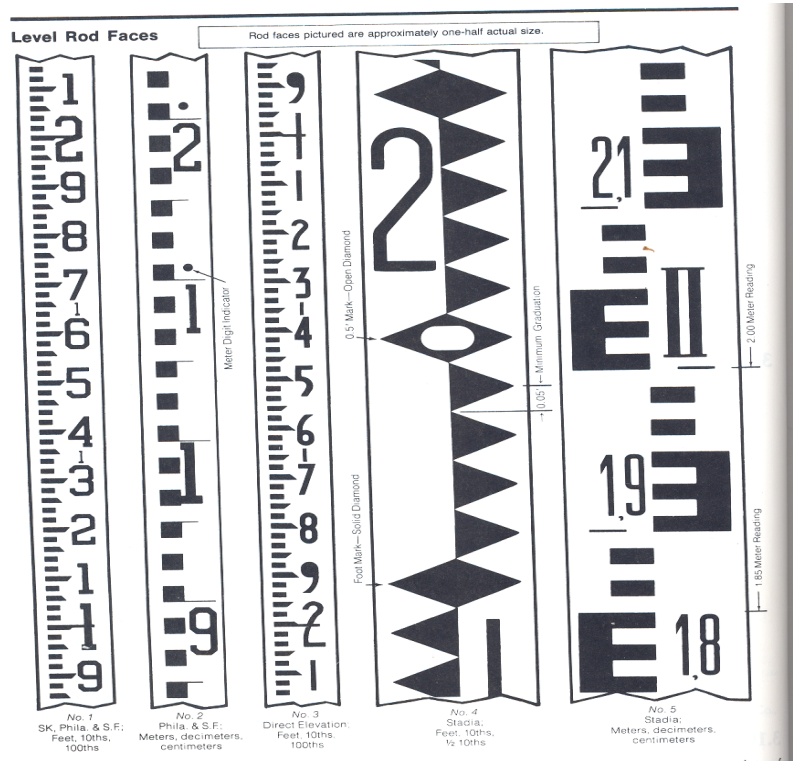

**Fig. 5.7.** Traditional rectangular cross-section leveling rods showing a variety of graduation markings.



**Fig 5.8.** Circular rod level

## **5.9 Leveling Procedures**

### **A. Setting Up and Leveling the Instrument**

The level must be securely mounted on top of a three-legged wooden or aluminum stand called a *tripod*. Two basic types include an *adjustable-leg tripod* and a *fixed-leg tripod*. The adjustable leg model is convenient for setups on steeply sloping ground and is more easily transported when closed. The fixed leg type is more rigid and provides greater stability for precise leveling work. The instrument is either screwed directly on to the tripod head or attached with a fastening-screw assembly.





(a) Adjustable leg tripod

(b) Straight leg tripod

**Fig. 5.9.** Tripod stands



(c) Tripod head adaptor

**Fig. 5.10.** Tripod head adaptor



Each leg of a tripod has a pointed metal shoe at the end. The tripod is setup with the legs well spread and pressed firmly in to the ground. If the surface is hard or paved, each tripod leg should be placed in a crack in the pavement; the leg hinges may also be tightened for extra friction.

### B. Leveling a Three-Screw Instrument

Three leveling screws first approximately level some tilting levels and nearly all-automatic levels. The level position is indicated by the coincidence of a *spirit bubble* and 'bull's-eye' of a circular level vial. Any one of the three screws can be rotated separately. *The bubble will move towards any screw turned clockwise.* It always must be kept in mind that turning any screw on a three-screw level slightly changes the HI. Never turn a leveling screw of a three-screw leveling head once a BS reading has been taken and an HI established.

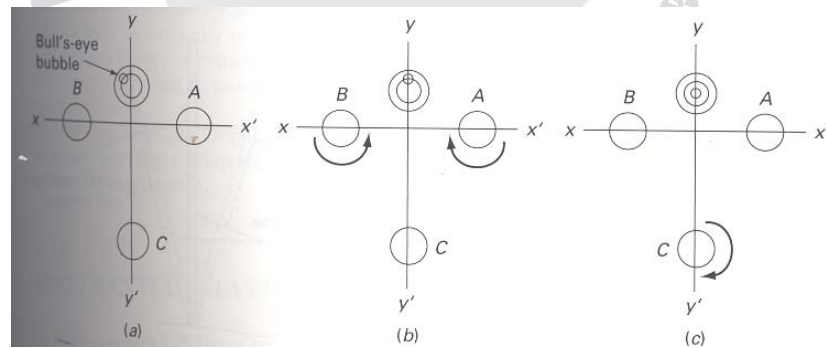

**Fig. 5.11.** Leveling a three-screw instrument.

### **C. Leveling Mistakes and Errors**

As with any surveying operation, blunders must be eliminated and errors minimized while running levels. Misreading the rod is a common blunder; it can be avoided by always having the rod person check the reading with pencil point or target. Note-keeping mistakes can be particularly troublesome. The computations of HI and turning point (TP) elevation should be done in the field, as the work progresses. A simple arithmetic check at the end of the leveling run can be made to avoid addition or subtraction errors.

#### **a. Random Errors**

Unavoidable accidental errors may occur when running levels, for several reasons. For example:

- The level rod may not be precise when the reading is taken.
- Heat waves from the ground make it difficult to read.
- On windy day, slight vibration of the cross hair can cause small errors in the reading.
- The instrument may be slightly out of level if the spirit level is not perfectly centered.

Accidental errors can be minimized with a properly maintained and adjusted instrument if the following steps are taken:

1. Make sure the tripod legs are secure and firmly anchored before leveling the instrument.

2. Check to see that the bubble is centered before each reading; re-center it if necessary.
3. Do not lean on the tripod legs when reading the rod.
4. Have the rod person use a rod level, to make sure it is held vertically.
5. Try to keep the line of sight about 0.5m above the ground when positioning the instrument.
6. Do not use very long BS and FS reading.

**b. Systematic / Instrumental Errors**

- Incorrect length of the rod.
- When the bubble tube axis is not perpendicular to the standing axis of the instrument
- When the line of sight of the telescope is not parallel to the bubble axis.

If the line of sight of a level is not exactly horizontal when the bubble is centered, but slopes either up or down, it will slope by the same amount for any direction of the telescope. As long as the horizontal lengths of the BS and FS are the same, from any given instrument position to the rod, the line of sight will intercept the rod held on each point with exactly the same error in height. But since one of the sights is a plus sight (+) and other a minus sight (-), the two errors will cancel each other out in the leveling computation.

### D. Checking For Mistakes

When the survey is complete, an arithmetic check is done; this simply assures that no mistakes in addition or subtraction was made in the 'HI' and 'elevation.' columns of the field notes. Sometimes, the line of levels is run back to benchmark or the starting point. This is called a *closed loop or level circuit*. Any leveling survey should close back either on the starting benchmark or on some other point of known elevation, in order to provide a check against blunders.

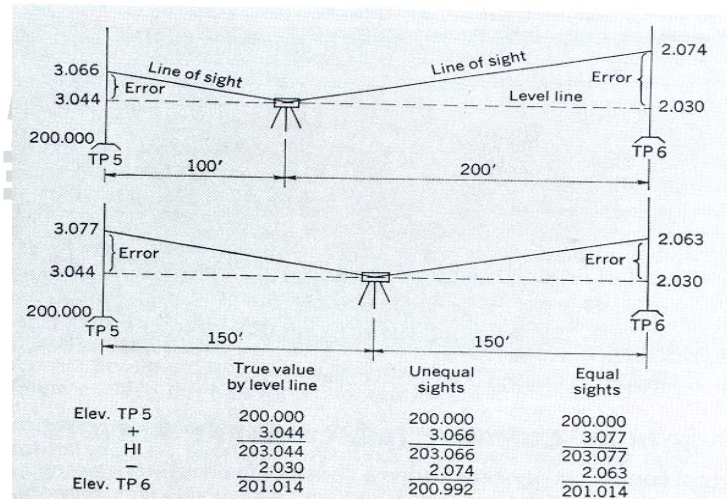

**Fig. 5.12.** When the horizontal length of the foresight (plus ) and backsight (minus) are the same, the systematic error of adjustment of the level is cancelled.



For horizontal sight, refraction  $R_m$  in meters is expressed by the formula

$$R_m = 0.011L^2$$

The combined effect of curvature of the earth and refraction,  $h$  is approximated as

$$h_m = 0.0675L^2$$

Where  $h_m$  is in meters.

For example, for a 100m length there is about 0.00067m length of error.

### 3. Trigonometric Leveling

Trigonometric leveling is an indirect procedure; the vertical distances are computed from vertical angle and horizontal or slope distance data. It is also applied for topo work over rough terrain or other obstacles.

The difference in elevation between two points can be determined by measuring

1. The inclined or horizontal distance between them and
2. The zenith angle or the vertical angle to one point from the other

**N.B:** Zenith angles and Vertical angles are both measured in a vertical plane. Zenith angles are measured downward from the vertical, and Vertical angles are measured up or down from the horizontal.

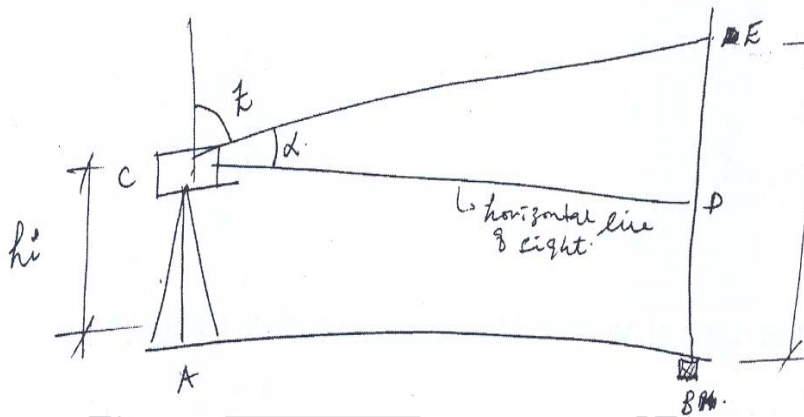

**Fig.** trigonometric leveling for plane surveying

Thus, in figure 5.14. If slop distance  $S$  and zenith angle  $Z$  or vertical angle  $\alpha$  between C&D are measured, then  $V$ , the elevation difference between C and D, is

$$V = S \cos \alpha$$

OR

$$V = S \sin Z$$

Alternatively, if horizontal distance  $H$  between C and D is measured, then  $V$  is

$$V = H \cot z$$

OR

$$V = H \tan Z$$

The difference in elevation ( $\Delta$  elev) between points A and B is given by

$$\Delta \text{ elev} = h_i + V - r$$

Where  $hi$  is the height of the instrument above point A and  $r$  is the reading on the rod held at B when zenith angle  $z$  or vertical angle  $\alpha$  is read. If  $r$  is made equal to  $hi$ , then these two values cancel in equation above, and simplifies the computations.

Note the distinction between HI and  $hi$ . Although both are called Height of Instrument, HI is *the elevation of the instrument above datum*, while  $hi$  is *the height of the instrument above an occupied point*.

For shorter lines (up to about 1000ft or m in length) elevation differences obtained in trigonometric leveling are appropriately computed and depicted by the above equations. For longer lines, however, earth curvature and refraction become factors that must be considered. Fig. 5.15 illustrates the situation. Here an instrument is set up at C over point A. Sight D is made on a rod held at point B, and zenith angles  $z_m$  or vertical angles  $\alpha_m$  is measured. The true difference in elevation between A and B is vertical distance HB between level lines through A and B, which equal to  $HG + GF + V - ED - r$ . Since HG is the instrument height  $hi$ , GF is earth curvature C, and ED is refraction R, the elevation difference can be written as:

$$\Delta \text{ elev} = hi + V + (C-R) - r$$





course as lines become extremely long, this assumption does not hold. However, for lengths within the practical range, errors caused by this assumption are negligible.

The  $h_i$  used in the equation  $\Delta \text{ elev} = h_i + V + (C-R) - r$ ; can be obtained by simply measuring the vertical distance from the occupied point up to the instrument's horizontal axis (axis about which the telescope rotates) using a graduated rod or rule. An alternative method can be used to determine the elevation of a point that produces accurate results and does not require measurement of the  $h_i$ . In this procedure, the instrument is setup at a location where it is approximately equidistant from a point of known elevation (Bench mark) and the one whose elevation is to be determined. The slope distance and zenith (or vertical) angle are measured to each point. Because the distances from the two points are approximately equal, the curvature and refraction errors cancel. Since, the same instrument set up applies to both readings, the  $h_i$  values cancel, and if the same rod reading  $r$  is sighted when making both angle readings, they cancel. Thus the elevation of the unknown point is simply the bench mark elevation, minus  $V$  calculated from the bench mark, plus  $V$  computed for the unknown point, where the  $V$  values are obtained using the above equations.

### Error of Closure and Precise Leveling

The relative accuracy required for a vertical control or leveling survey depends on its purpose. In countries where there are sets of standards and specifications as a guide line for surveyors, standards are expressed in terms of an *allowable error of closure* instead of a relative accuracy ratio.

The allowable error of closure is a function of the length or total horizontal distance of the leveling line or circuit. The function is expressed in the following form:

$$\text{Error} = \text{Constant} \times \sqrt{\text{distance}}$$

*The higher the order of the accuracy, the smaller the constant.*  
For example, for a level circuit with a total length of 2000 m, at the third order accuracy, the maximum error of closure would be  $12\sqrt{2} = 17$  mm.

**Table 5. 3.** Accuracy standards for vertical control surveys

Order	Maximum allowable error of closure, mm	Applications
<b>First</b>		
Class I	$\pm 3\sqrt{k}$	Provides basic framework for the national control network and precise control of large engineering projects and scientific studies
Class II	$\pm 4\sqrt{k}$	
<b>Second</b>		
Class I	$\pm 6\sqrt{k}$	Adds to the basic framework, for major engineering projects
Class II	$\pm 8\sqrt{k}$	
Third	$\pm 12\sqrt{k}$	Serves as vertical reference for local engineering, topo, drainage, and mapping projects

### **Adjusting Benchmark Elevations**

The importance of running a line of levels back to the starting benchmark, or to some other fixed point of known elevation is to avoid blunders. There is really no way to assure that a blunder was not made in the work with out closing the level circuit one way or the other. It is much less expensive to find and correct a blunder in the field by closing the loop than to have to return and repeat the work at a later date.

When the line of levels or level circuit is completed, there is usually some small difference between the given fixed elevation of the benchmark and the observed elevation arrived at in the leveling notes. If the arithmetic check works out all right, then it may be assumed that the discrepancy is due to random or accidental errors.

Suppose a leveling survey closes within the desired order and class of accuracy; in other words, there is an error of closure, but it is acceptable. The problem now is to distribute that total error of closure among the various intermediate benchmarks and to adjust the circuit so that it closes exactly. In doing this for single level line or circuit, it may be assumed that the elevation error at each point along the circuit or line of levels is directly proportional to the distance of the point from the starting benchmark. The relationships for adjusting the leveling line or circuit may be summarized as follows:

$$\text{Correction} = \text{Error of Closure} \times \frac{\text{distance from the starting benchmark}}{\text{Total length of level run}}$$

$$\text{Error of Closure} = \text{given benchmark elevation} - \text{Observed benchmark elevation}$$

$$\text{Adjusted Elevation} = \text{Observed elevation} + \text{Correction}$$

## 5.7. Profile Leveling

Profile leveling is one of the most common applications of running levels and vertical distance measurement for the surveyor. The results are plotted in the form of a profile, which is a drawing that shows a vertical cross section. Profiles are required for the design and construction of roads, curbs, sidewalks, pipelines etc. In short, profile leveling refers to the process of determining the elevation of points on the ground at mostly uniform intervals along continuous line.

### Field Procedure

Profile leveling is essentially the same as benchmark leveling, with one basic difference. At each instrument position, where an HI is determined by a back sight rod reading on a benchmark or turning point, several additional foresight readings may be taken on as many points as desired. These additional readings are called *rod shots*, and the elevation of all those points is determined by subtracting the rod shot from the HI at that instrument location.

### Plotting the Profile

The profile drawing is basically a graph of elevations, plotted on the vertical axis, as a function of stations, plotted on horizontal axis. A gridded sheet called *profile paper* is used to plot the profile data from the field book. All profile drawings must have a proper title block, and both axes must be fully labeled with stations and elevations.

The elevation or elevation scale is typically exaggerated; that is, it is 'stretched' in comparison to the horizontal scale. For example the vertical scale might be 10 times larger.

The horizontal line at the bottom of the profile does not necessary have to start at zero elevation.

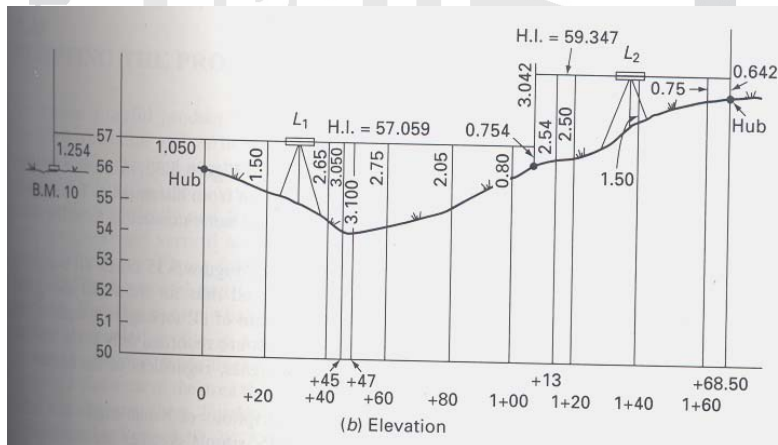

Fig. 5. 14. Profile leveling

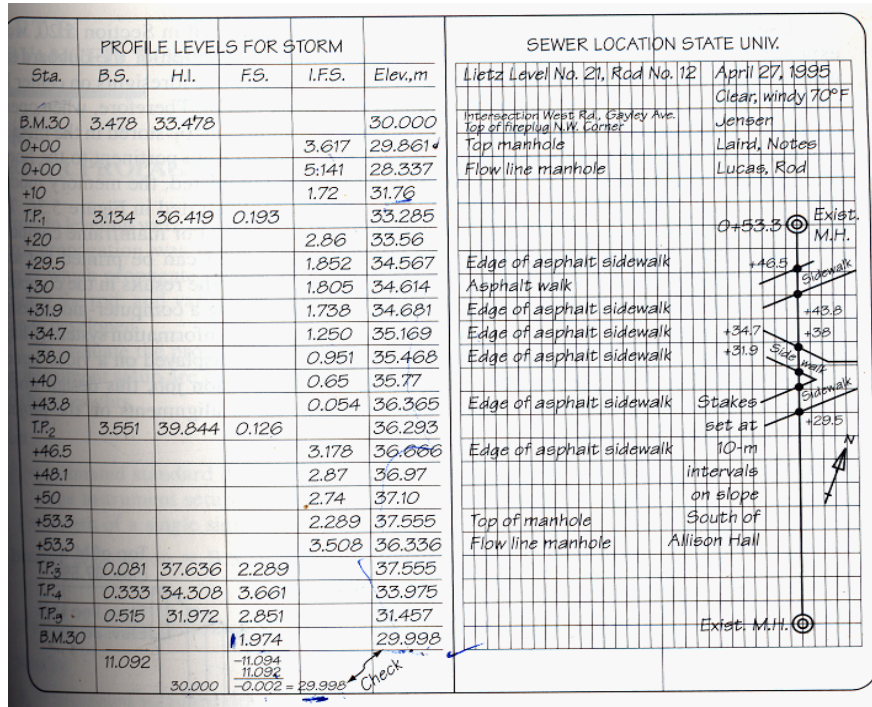

Fig. 5.15. Profile notes in metric units.

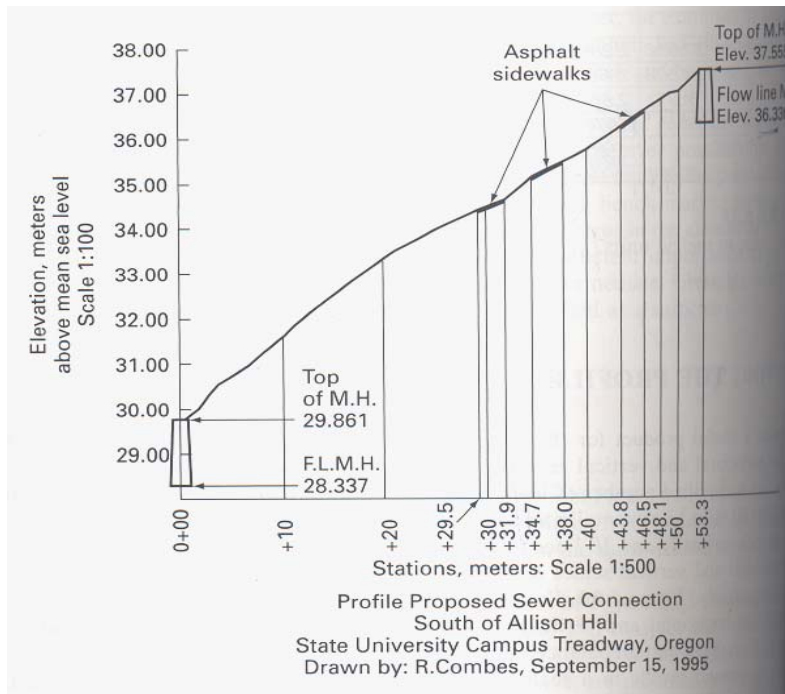

Fig. 5.16. Plotted profile.

## 5.8. Cross-Section Leveling

The term cross-section generally refers to a relatively short profile view of the ground, which is drawn perpendicular to the route centerline of a highway or other types of linear projects. Cross-sectional drawings are particularly important for estimating the earthwork volumes needed to construct a roadway; they show the existing ground elevations, the proposed cut or fill side slopes, and the grade elevation for the road base.



There is really no difference in procedure between profile and cross-section leveling except for the form of the field notes. Cross-section rod shots are usually taken during the route profile survey from the same instrument positions used to take rod shots along the centerline. Cross-section data are obtained at the same locations along the route that are used for the profile rod-shot stations.

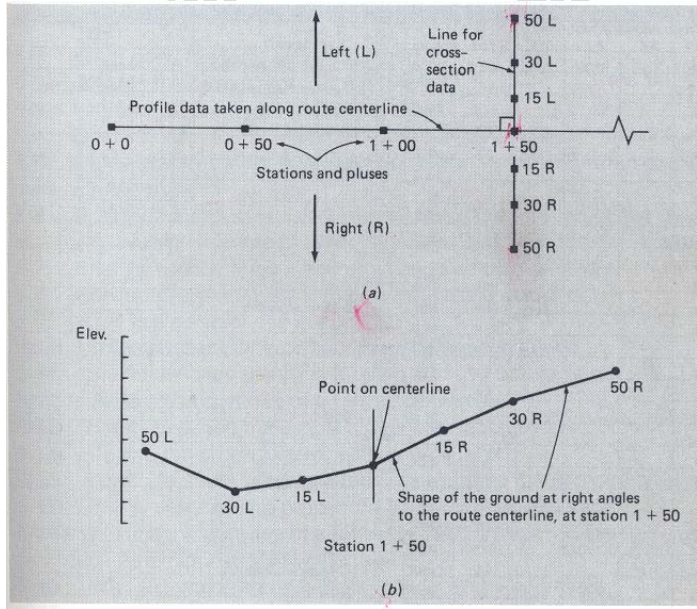

**Fig. 5.17.** (a) Top view showing the route center line and the line for cross-section leveling at station 1+50.  
 (b) the cross-section showing ground elevations at points left and right of the center line.

Profile 21 Cross sections - new road				Ch. & Recorder - Roberts A. Smith Rod Jones		7/15/85 Clear 80°F	
Sta	BS	HI	FS	Rod	Elev		
BM6	3.53	83.77			90.24	Precise BM disc set in	Level
0+0						top step # 234 Maple Ave	Berger # 12978
50 L				4.2	89.6	ROW	
30 L				6.9	87.1	Bottom of swale	
15 L				5.6	88.2		
¢				5.2	88.6		
15 R				4.1	89.7		
30 R				3.4	90.4		
50 R				2.6	91.2	ROW	
0+50							
50 L				4.4	89.4	ROW	
30 L				6.9	86.9	Bottom of swale	
15 L				5.8	88.0		
¢				5.5	88.3		
15 R				4.3	89.5		
30 R				3.7	90.1		
50 R				2.8	91.0	ROW	
1+00							
50 L				4.7	89.1	ROW	
30 L				7.3	86.5	Bottom of swale	
15 L				6.1	87.7		
¢				5.7	88.1		
15 R				4.5	89.3		
23 R				4.0	89.8	Change in slope	
50 R				3.1	90.7	ROW	

Fig. 5.18. Cross-section field notes.

## 5.9. Three-Wire Leveling

Using the stadia cross hairs found on most levels, one can perform leveling. Each back sight (BS) and fore sight (FS) is recorded by reading the stadia hairs in addition to the horizontal cross hair. The three readings thus obtained are averaged to obtain the desired value.

The stadia hairs (wires) are positioned an equal distance above and below the main cross hair and are spaced to give

1.00 ft (m) of interval for each 100 ft (m) of horizontal distance that the rod is away from the level.

The recording of three readings at each sighting enables the surveyor to perform a relatively precise survey while using ordinary levels. Readings to the closest thousandth of a foot (mm) are estimated and recorded. The leveling rod used for this type of work should be calibrated to ensure its integrity.

B.M. #17 to B.M. 201      JONES-NOTES      Job ROD #19;      INST. T.L. 35  
 (RETURN RUN ON P.48)      SMITH-X      Date      MAR 3 2000      Page  
    BROWN-ROD  
    GREEN-ROD

STA.	B.S.	DIST.	F.S.	DIST.	ELEV.	DESCRIPTION	SET	IN	WA
BM #17					186.2830	BRONZE PLATE	SET	IN	WA
	0.825		1.775						
	0.725	10.0	1.673	10.2	+0.7253				
	0.626	9.9	1.572	10.1	187.0083				
	2.176	19.9	5.020	20.3	-1.6733				
	+0.7253		-1.6733						
T.P. #1					185.3350	N. LUG TOP FLANGE FIRE			
	0.698		1.750			MAIN ST. OPP. CIVIC #181			
	0.571	12.7	1.620	13.0	+0.5710				
	0.444	12.7	1.490	13.0	185.9060				
	1.713	25.4	4.860	26.0	-1.6200				
	+0.5710		-1.6200						
T.P. #2					184.2860	N. LUG TOP FLANGE FIRE			
	1.199		2.509			MAIN ST. OPP. CIVIC #163			
	1.118	8.1	2.427	8.2	+1.1180				
	1.037	8.1	2.343	8.4	185.4040				
	3.354	16.2	7.279	16.6	-2.4263				
	+1.1180		-2.4263						
BM. 201					182.9777	BRONZE PLATE SET IN E			
						OF RETAINING WALL ---			
Σ	+2.4143	61.5m	-5.7196	62.9m					
ARITHMETIC CHECK: 186.283 + 2.4143 - 5.7196 =					182.9777				

Fig. 5.19. Survey notes for three-wire leveling.

## Exercise

1. A differential leveling loop began and closed on BM bridge (elevation 1237.28 ft). The BS and FS distances were kept approximately equal. Readings taken in order are 8.59 on BM bridge, 6.54 and 4.87 on TP1, 7.50 and 6.08 on BM X, 7.23 and 2.80 on TP2, and 1.11 on BM bridge. Prepare, check and adjust the notes.
2. A level setup midway between X and Y reads 5.18 on X and 6.80 on Y. When moved within a few feet of X, readings of 4.74 on X and 6.32 on Y are recorded. What is the true elevation difference, and the reading required on Y to adjust the instrument?
3. Reciprocal leveling gives the following readings in feet from setup near A: on A, 2.071; on B, 8.254, 8.259 and 8.257. At the setup near B, 9.112; on A, 2.926, 2.930, and 2.927. The elevation of B is 1099.60. Compute the misclosure and the elevation of A.
4. Prepare a set of three-wire leveling notes for the data given and make the page check. The elevation of BM X is 230.054m. Rod readings(in meter) are:  
BS on BM X: H = 1.683, M = 1.453, L = 1.224; FS on  
TP1: H = 2.959, M = 2.707, L = 2.454; BS on  
TP1: H = 2.254, M = 2.054, L = 1.854; FS on  
BM Y: H = 1.013, M = 0.817, L = 0.620.

5. Prepare a set of profile leveling notes for the data listed and show the page check. The elevation of BM A is 1275.39 ft, and the elevation of BM B is 1264.78 ft. Rod readings are: BS on BM A, 5.68; IFS on 1+00, 4.3; FS on TP1, 9.56; BS on TP1, 10.02; IFS on 2+00, 11.1; on 3+00, 6.1; FS on TP2, 8.15; BS on TP2, 3.28; ifs on 3+64, 1.51; on 4+00, 3.1; on 5+00, 6.4; FS on TP3, 7.77; BS on TP3, 3.16; FS on BM B, 7.23.
6. If the elevation on a certain project at stations 10+00 and 14+00 are 1232.47 and 1248.06, respectively, what is the percent grade connecting these points?
7. In trigonometric leveling from point A to point B, the slope distance and zenith angle measured at A were 23051.82 ft and  $83^{\circ}41'16''$ . At B these measurements were 23051.85ft and  $96^{\circ}21'31''$ , respectively. If the instrument and rod target height were equal, calculate the difference in elevation from A to B.
8. Prepare a set of profile leveling notes for the survey illustrated. In addition to computing all elevations, show the arithmetic check and the resulting error of closure. And plot the profile graph with appropriate scale.

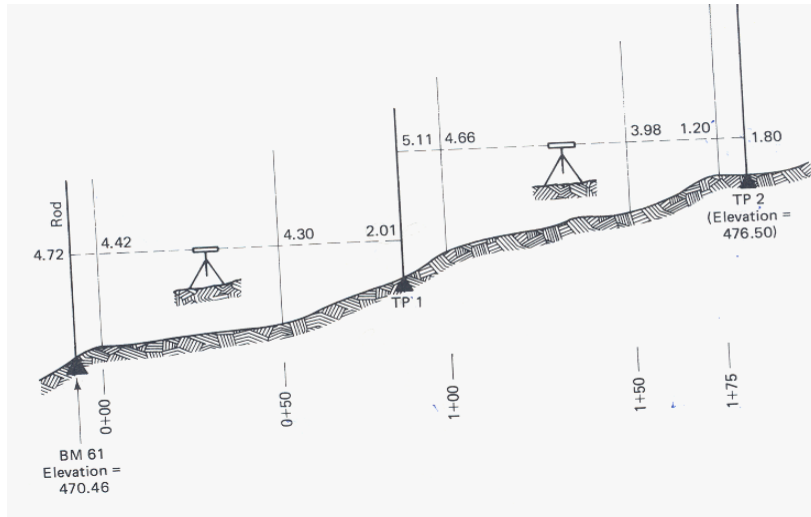

9. Reduce the following set of municipal cross-sectional notes.

Station	BS	HI	IS	FS	Elevation
BM41	4.11				319.70
TP#13	4.10			0.89	
12+00					
50 ft L			3.9		
18.3 L			4.6		
C <sub>L</sub>			6.33		
20.1 R			7.9		
50 R			8.2		
13+00					
50L			5.0		
19.6L			5.7		
C <sub>L</sub>			7.54		
20.7R			7.9		
50R			8.4		
TP#14	7.39			1.12	
BM S.22				2.41	

10. A pre-engineering baseline was run down a very steep hill. Rather than measure horizontally downhill with the steel tape, the surveyor measured the vertical angle with a theodolite and the slope distance with a 200' steel tape. The vertical angle was  $-21^{\circ}26'$  turned to a point on a plumbed range pole 4.88 ft above the ground. The slope distance from the theodolite to the point on the range pole was 148.61 ft. The theodolite optical center was 4.66 ft above the upper base line station at 110+71.25.
- If the elevation of the upper station was 829.76, what is the elevation of the lower station?
  - What is the chainage of the lower station?

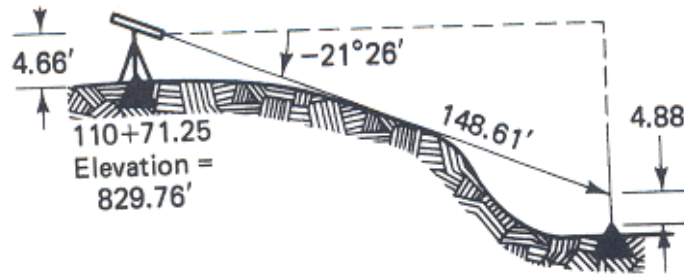

11. Reduce the following set of differential leveling notes and perform the arithmetic check.
- Determine the order of accuracy.
  - Adjust the elevation of BM K110. The length of the level run was 780 m with setups equally spaced. The elevation of BM 132 is known to be 170.198.

Station	BS	HI	FS	Elevation
BM 130	0.702			171.226
TP#1	0.970		1.111	
TP#2	0.559		0.679	
TP#3	1.744		2.780	
BMK110	1.973		1.668	
TP#4	1.927		1.788	
BM132			0.888	

12. Plan-view sketches of benchmark leveling runs are shown below. Along each line representing a sight is the value of the rod reading for that sight. The numbering of the TPs shows the direction of level run. Place the data in the form of the field notes. Include the arithmetic check. Assume that the average length of each BS and FS is 40m; determine the order of accuracy of the survey.

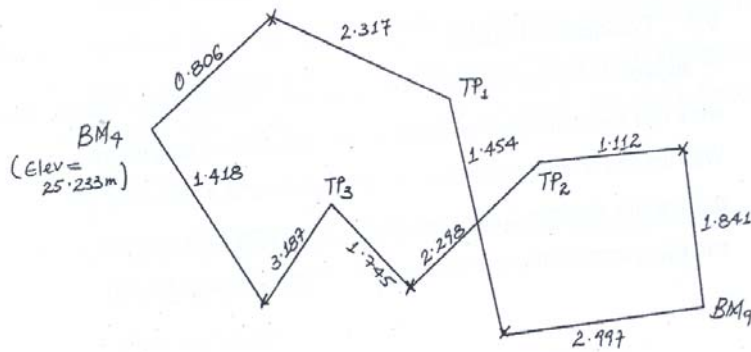



# CHAPTER SIX

## TACHEOMETRY

### 6.1 LEARNING OBJECTIVES

At the end of this chapter, the student will be able to:

1. Define and state the principles of stadia
2. Measure distance and angles with the stadia principle
3. Identify potential sources of errors
4. Take corrective actions for identified errors.

### 6.2 Introduction

The stadium (Tacheometry) is a rapid and efficient way of indirectly measuring distances and elevation differences. The accuracy attainable with stadia is suitable for lower order trigonometric leveling, locating topographic details for mapping, measuring lengths of back sights and fore sights in differential leveling, and making quick checks of measurements made by higher order methods.

### 6.3. Principles of Stadia

In addition to the center horizontal cross hair, a theodolite or transit reticles for stadia work has two additional horizontal cross hairs spaced equidistant from the center one. With the line of sight horizontal and directed towards a graduated rod held vertically at a point some distance away, the interval

appearing between two stadia hairs of most surveying instruments is precisely 1/100 of the distance of the rod.

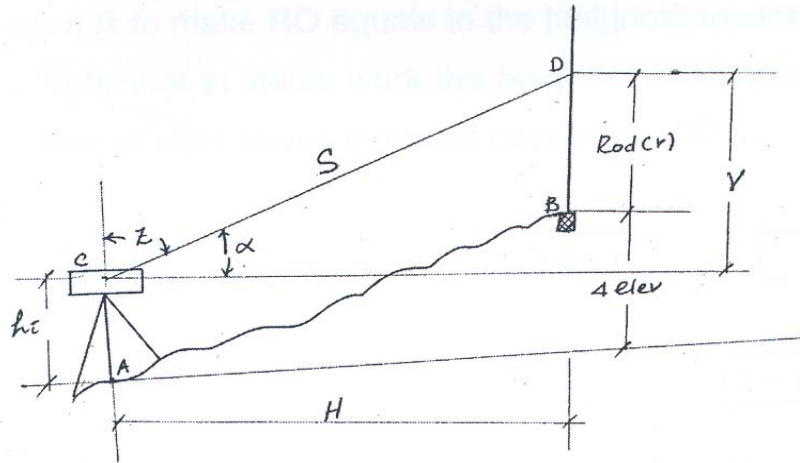

**Fig 6.1.** Horizontal stadia measurement

The stadia method is based on the principle that in similar triangles, corresponding sides are proportional. In the figure 6.1. , depicting a telescope with a simple lens, light rays from points A and B passing through the lens center from a pair of similar triangles AmB and amb. Here AB = l is the *rod intercept (stadia interval)*, and ab=l is the spacing between stadia hairs.

Standard symbols used in stadia measurements and their definitions are as follows:

f = focal length of lens

i = spacing between stadia hairs

**f/i**=stadia interval factor, usually 100 and denoted by K

**I**=rod intercept, also called stadia interval  
**c**=distance from instrument center (vertical axis) to objective lens center.  
**C**=stadia factor= $c+f$   
**d**=distance from focal point F in front of the telescope to face of the rod.  
**D**=distance from instrument center to face =  $C+d$

From similarity of triangles,

$$d/f = I/i$$

or

$$d = I(f/i) = KI$$

Thus,

$$D = KI + C$$

The objective lens of an internal focusing telescope remains fixed in position, while a movable negative focusing lens between the objective lens and the planes of the cross-hairs change direction of the light rays. As a result, the stadia constant 'C', is so small that it can be assumed equal to zero and drop out. Thus the equation for distance on a horizontal stadia sight reduces to:

$$D = KI$$

To determine the stadia factor K, rod intercept I for a horizontal sight of known distance D is read.

## 6.4 Stadia Measurement on an Inclined Sights

Most stadia shots are inclined because of varying topography, but the intercept is read on a plumbed rod and the slope length reduced to horizontal and vertical distances.

In figure 6.2., an instrument is set over point M and the rod held at O. With the middle cross-hair set on point R to make RO equals to the height of the instrument  $EM = h_i$ , the vertical angle is  $\alpha$ . Note that in stadia work the height of instrument  $h_i$  is again defined as the height of the line of sight above the point occupied.

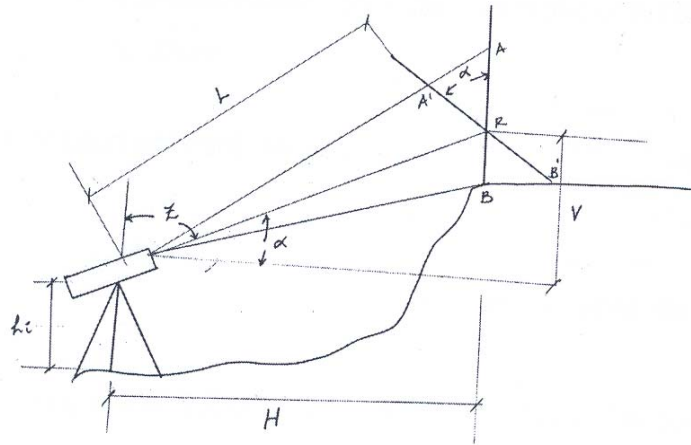

Fig. 6.2. Inclined stadia measurement

Let L represent slope length ED, H the horizontal distance EG = MN, and V the vertical distance RG = ON. Then

$$H=L\cos\alpha \dots\dots\dots(a)$$

$$V=L\sin\alpha \dots\dots\dots(b)$$

If the rod could be held normal to the line of sight at point O, a reading A'B', or I', would be obtained, making

$$L=KI' \dots\dots\dots(c)$$

Since it is not practical to hold the rod at an inclined angle  $\alpha$ , it is plumb and reading AB or I taken. For small angle at R on most sights, it is sufficiently accurate to consider angle AA'R as a right angle. Therefore,

$$I'=I\cos\alpha \dots\dots\dots(d)$$

And substituting (d) in to (c)

$$L=KI\cos\alpha \dots\dots\dots(e)$$

Finally, substitute (e) in to (a), the equation for horizontal distance on an inclined stadia sight is

$$H=KI\cos^2\alpha$$

If zenith angles are read rather than vertical angles, then the horizontal distance is given by

$$H=Kl\sin^2z$$

Where  $z$  is the zenith angle, equal to  $90^\circ - \alpha$

The vertical distance is found by substituting (e) in to (b), which gives

$$V=Kl\sin\alpha\cos\alpha$$

OR

$$V=Kl\sin z\cos z$$

If the trigonometric identity  $(1/2)\sin 2\alpha$  is substituted for  $\sin\alpha\cos\alpha$ , the formula for vertical distance becomes

$$V=1/2Kl\sin 2\alpha$$

OR

$$V=1/2Kl\sin 2z$$

In the final form generally used,  $K$  is assigned 100 and the formulas for reduction of inclined sight to horizontal and vertical distances are

$$H=100l\cos^2\alpha$$

OR

$$H=100l\sin^2z$$

and

$$V=50l\sin 2\alpha$$

OR

$$V=50l\sin 2z$$

From the figure 6.2, the elevation of point O is:

$$\text{Elev}_O = \text{elev}_M + h_i + V - R$$

From the above equation, the advantage of sighting an R-value that is equal to the  $h_i$  when reading the vertical or zenith angle is evident. Since the rod reading and  $h_i$  are opposite in sign, if equal in magnitude they cancel each other and can be omitted from the elevation computation.

Note: A ratio of error of 1/300 to 1/500 can be obtained for a stadia traverse run with ordinary care and reading both foresights and back sights.

## **6.5. Sources of Errors in Stadia Work**

Errors that occur in stadia work are both instrumental and personal, and include the following:

### **6.5.1 Instrumental Errors**

1. Improper spacing of stadia wires
2. Index error in vertical or zenith angles
3. Incorrect length of rod graduations
4. Line of sight not established truly horizontal by level vials

### 6.5.2 Personal Errors

1. Rod not held plumb (avoid by using a rod level)
2. Incorrect rod reading resulting from long sights
3. Careless leveling for vertical-arc readings
4. Mistakes:
  - a) Mistakes in reading the rod intercept
  - b) Use of an incorrect stadia interval factor
  - c) Waving the rod
  - d) Index error applied with wrong sign
  - e) Confusion of plus and minus vertical angles read with a transit.

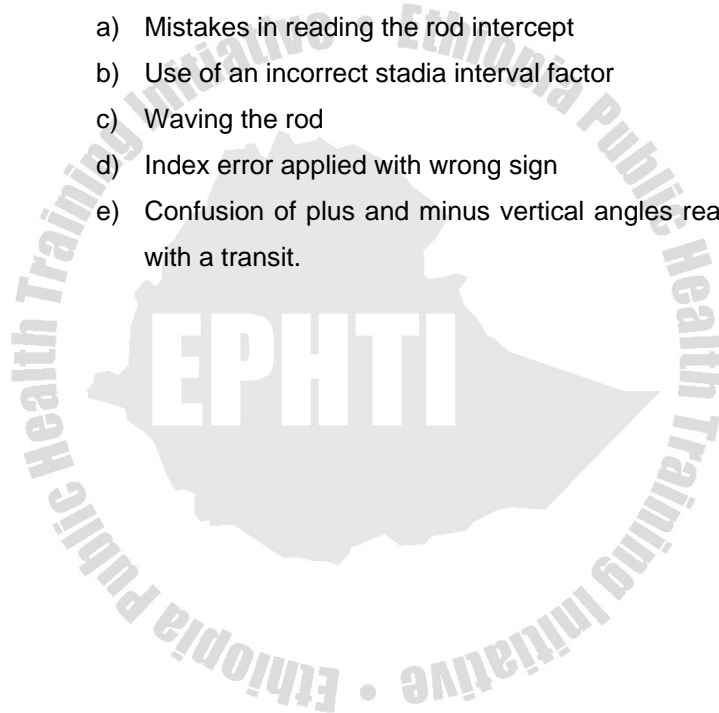



## Exercise

- The tacheometric observations in table below were taken along the line of a proposed roadway at approximately 20m intervals.

Instrument station	D (approx. chainage 60 m)				
Instrument height	1.45 m				
Reduced level of station	234.21 m AOD				
		<i>Stadia</i>			
<i>Target station</i>	<i>Vertical angle</i>	<i>Top</i>	<i>Mid</i>	<i>Bottom</i>	<i>Remarks</i>
A	−4° 20′	1.750	1.450	1.140	Chainage 0 m
B	−4° 20′	1.400	1.200	1.000	Approx. 20 m
C	−4° 20′	1.210	1.105	1.000	Approx. 40 m
E	−3° 00′	1.200	1.100	1.000	Approx. 80 m
F	−3° 00′	1.650	1.450	1.250	Approx. 100 m

Instrumental constant  $m = 100$ .

Calculate, the reduced level and true chainage for each station.

- In determining the elevation of point A and the distance between two points, A and B, a theodolite is set up at A and the following data are obtained:  $Z=92^{\circ}45'$ , stadia interval = 1.311m,  $h_i = 1.28$ m, and the line of sight at 2.62m on rod. The instrument constant  $K=100$  and  $C=0$ . The elevation of B is 38.28m. Compute the distance AB and elevation of point A.

3. Elevation of  $BM_{10}$  is 42.852m. The stadia interval factor is 100.00 and  $C=0$ . Determine elevation for the turning points and  $BM_{11}$ . Record notes and elevations in a proper note form.

Station	Back sight			Fore sight		
	Stadia interval, m	Zenith angle	Rod, m	Stadia interval, m	Zenith angle	Rod, m
$BM_{10}$	1.031	$95^{\circ}30'$	2.41			
$TP_1$	2.041	$86^{\circ}30'$	2.06	1.506	$81^{\circ}50'$	1.00
$TP_2$	2.721	$96^{\circ}30'$	1.45	1.432	$94^{\circ}10'$	2.50
$TP_3$	2.012	$100^{\circ}00'$	2.04	0.901	$82^{\circ}30'$	0.24
$BM_{11}$				1.321	$92^{\circ}40'$	2.40

4. The elevation of station P is 345.67m. The  $hi$  of a transit set up over that station is 1.23m. When observing a rod held on station Q, the following data are recorded: Vertical angle =  $-9^{\circ}45'$ , lower staid hair = 0.83, center hair = 1.23, upper stadia hair = 1.63. Determine the distance between P and Q, and elevation of Q.

# CHAPTER SEVEN

## ANGLES, BEARING AND AZIMUTHS

### 7.1 Learning objectives

At the end of this chapter, the student will be able to:

1. Define the different types of angles with their instrument and unit of measurements.
2. Describe different meridians and system of designating direction of lines.
3. Explain magnetic declination and local attraction phenomena.

### 7.2. Introduction

Determining the locations of points and orientations of lines frequently depends on measurements of angles and directions. In surveying, directions are given by *bearings and azimuths*.

### 7.3 Angles

Depending on the plane in which they are measured, angles are classified as

- Horizontal angles
  - Basic measurement for determining bearing and azimuths.

➤ Vertical angles

- For trigonometric leveling
- For stadia measurement.
- For reducing measured slope distances to horizontal.

Angles are measured by

- Total station
- Theodolite
- Transit
- Compass
- By tape: - indirect measurement.

There are three basic requirements to determine an angle.

They are

1. Reference/starting lines
2. Direction of turning.
3. Angular distances (Values of the angle)

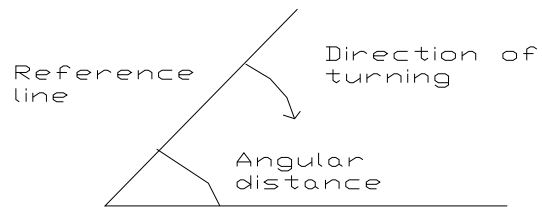

**Fig. 7.1.** The three determinants of an angle.

### Units of Measurements

- ✓ Decimal system
- ✓ Sexagesimal system
- ✓ Radians
- ✓ Centesimal system

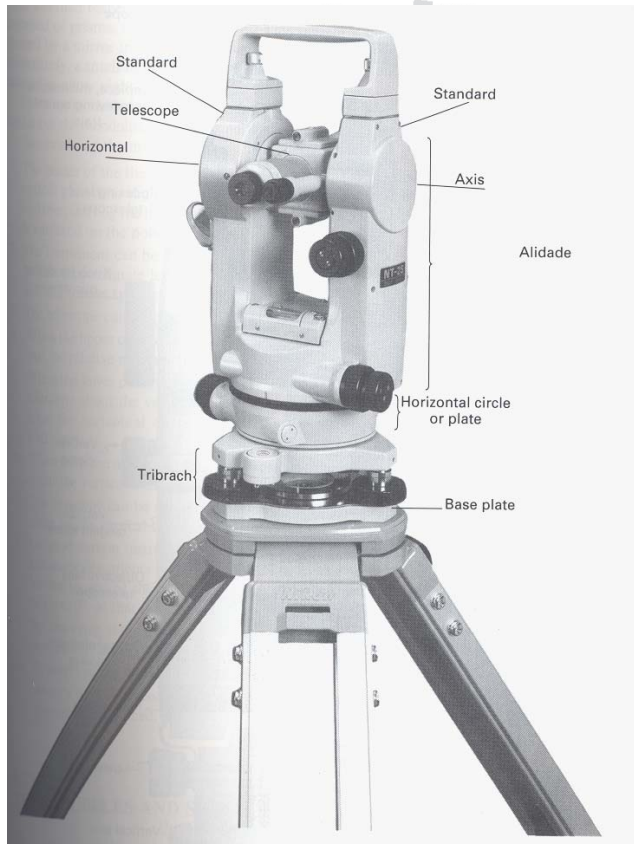

**Fig 7.2.** Theodolite

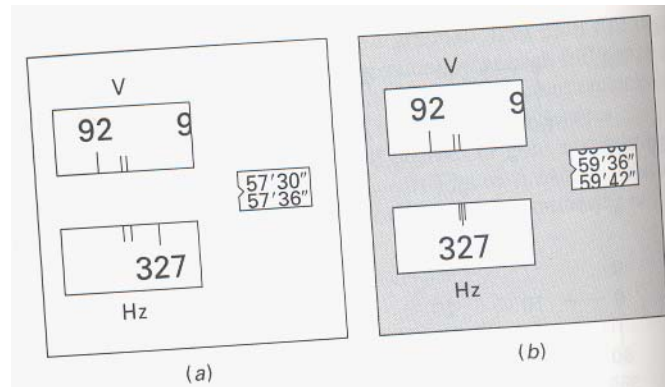

**Fig 7.3.** Horizontal circle reading using optical micrometer

- **Kinds of Horizontal Angles**

The kinds of horizontal angles most commonly measured in surveying are:

1. Interior angles.
2. Angles to the right.
3. Deflection angles.

1. **Interior Angles**

- ✓ They are measured on the inside of a closed polygon.
- ✓ Normally the angle at the apex within a polygon is measured.
- ✓ Then a check can be made on their value because the sum of all angles equals  $(n-2)180$
- ✓ Polygons (closed traverse) commonly used for boundary surveys.

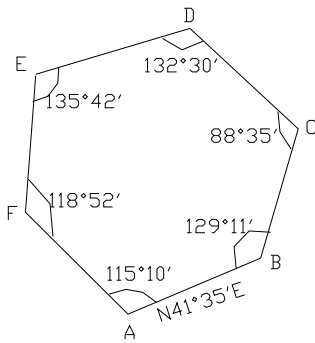
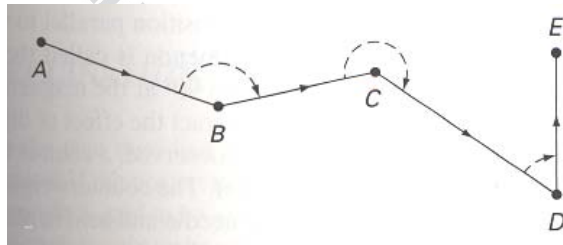

**Fig. 7.4.** Interior angles of a polygon

**Note:** Exterior angles are located outside a closed polygon and they provide a check, i.e. the sum of interior and exterior angles at any station must total  $360^{\circ}$ .

## 2. Angles To The Right

Angles may be determined by clockwise measurement from the preceding to the following line. Such angles are called *angles to the right* or *azimuths from the back line*.



**Fig. 7.5.** Angles to the right

### 3. Deflection Angles

- ✓ They are measured from an extension of the back line, to the forward station.
- ✓ They are measured to the right (c.w or +) or to the left (c.c.w or -) depending on the direction of the route.
- ✓ They are always smaller than  $180^{\circ}$ , and the direction of turning is identified by R or L.

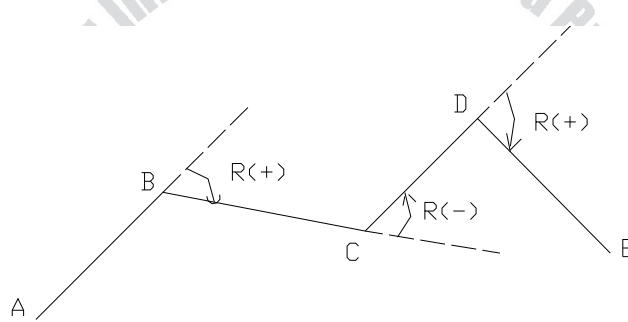

**Fig. 7.6.** Deflection angles

### 7.4. Direction of a Line

The direction of a line is the horizontal angle between it and an arbitrary closed reference line called a Meridian. (It is a line on the mean surface of the earth joining the north and south poles).

Different meridians are used for specifying a direction

- I. True Meridian: It is the north-south reference line that passes through the earth's geographic poles.



- II. Magnetic Meridians: defined by a freely suspended magnetic needle that is influenced by earth's magnetic field only.
- III. An Assumed Meridian: can be established by merely assigning any arbitrary directions. For example, taking certain street line to be true north.

#### **7.4.1 Bearings**

- ✓ Represent one system for designating directions of lines.
- ✓ A bearing is defined as the acute horizontal angle between a reference meridian and the line.
- ✓ The angle is measured from either the north or south towards the east or west, to give a reading smaller than  $90^{\circ}$
- ✓ True bearings/Magnetic bearings/Assumed bearings are measured from True /Magnetic/Assumed meridians.

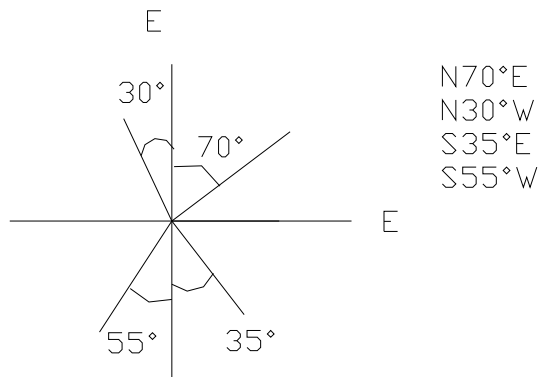

**Fig 7.7.** The bearing of a line is measured from the north or from the south (whichever is closer), in a clockwise or counterclockwise direction (whichever applies).

Assume that a compass is setup successively at points A, B, C and D and bearings read on lines AB, BA, BC, CB, CD and DC.

Bearings AB, BC and CD are called *Forward bearings* and BA, CB, DC are *Back bearings*.

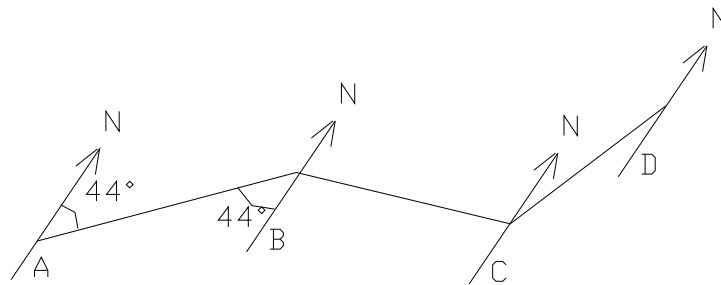

EX.  $N44^{\circ}E$  - FORWARD BEARINGS  
 $S44^{\circ}W$  - BACK BEARINGS

**Fig. 7.8.** Bearings

### 7.5 Azimuths

- ✓ They are horizontal angles measured clockwise from any reference meridians.
- ✓ They are generally measured from North.
- ✓ They can range from 0 to 360 and they do not require letters to identify the quadrant.

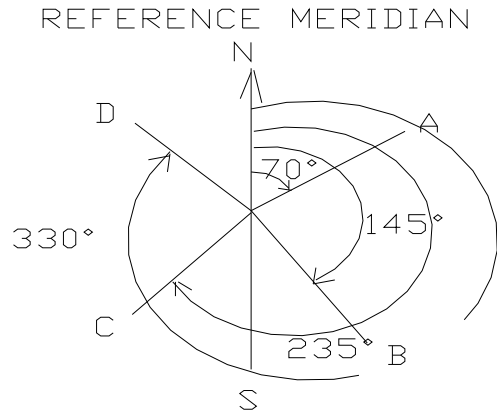

**Fig 7.9.** Azimuths

The forward direction of a line can be given by its Forward Azimuths and its reverse direction by its *Back tangent*. Forward azimuths are converted to back azimuths, and vice versa, by adding or subtracting  $180^{\circ}$ .

Examples:

Azimuths of OA =  $70^{\circ}$

Azimuths of AO =  $70^{\circ} + 180^{\circ} = 250^{\circ}$  (back azimuths)

Azimuths of OC =  $235^{\circ}$

Azimuths of CO =  $235^{\circ} - 180^{\circ} = 55^{\circ}$  (back azimuths)

Azimuths can be read directly by theodolite or EDM

### Comparison of Bearings and Azimuths

Most type of surveys employs traverses. Traverse is a series of connected lines whose lengths and angles have to be measured.

Eg. Boundary surveys, High way surveys, Topographic surveys

**Table 7.1.** Comparison of bearings and azimuths

BEARINGS	AZIMUTHS
- vary from 0 to 90°	- vary from 0 to 360°
- require two letters and numerical value	- require only numerical value
- may be true/magnetic/assumed, forward/back	- same as bearings.
- measured C.W or C.C.W	- are measured C.W only
- measured from N or S	- measured from North only.
Examples:	Examples:
N54°E	54°
S68°E	$180^{\circ} - 68^{\circ} = 112^{\circ}$
S51°W	$180^{\circ} + 51^{\circ} = 231^{\circ}$
N15°W	$360^{\circ} - 15^{\circ} = 345^{\circ}$

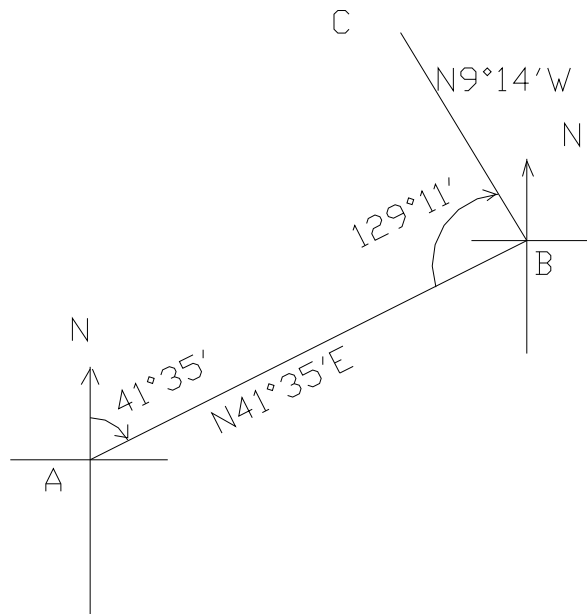

**Fig. 7.10. Bearings and angles**

### Computing Azimuths

Since azimuths are easier to work with, most surveys prefer them. Azimuths calculations are best made with the aid of sketches. But before azimuths or bearings are computed, it is important to check that the figure is geometrically closed:  $(n-2) \cdot 180$ .

N.B:

- If the computation is proceeding in C.C.W manner, add the interior angle to the back azimuth of the previously course.
- If the computation is proceeding in C.W manner, subtract the interior angle from the back azimuth of the previous course.

## **7.5. Compass Survey**

A compass consists of a magnetic steel needle mounted on a pivot at the center of a graduated circle. The needle aligns itself with the earth's magnetic field.

Magnetic declination is the horizontal angle from the true geographic meridians to the magnetic meridian. An east declination exists if the magnetic meridian is east of true north; a west declination occurs if it is west of true north. Because the magnetic pole positions are constantly changing, magnetic declinations at all locations also undergo continual changes. For any given time, the declination at any location can be obtained (if there is no local attraction) by establishing a true meridian from astronomical observations, and then reading a compass while sighting along the true meridian.

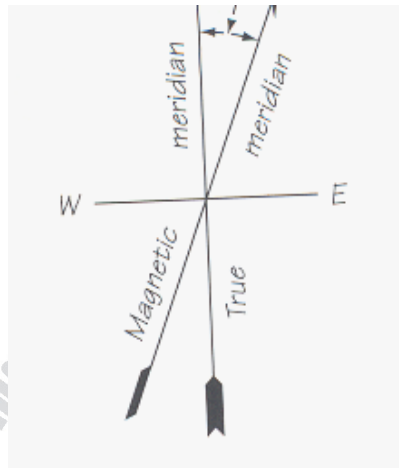

**Fig. 7.11.** Declination east

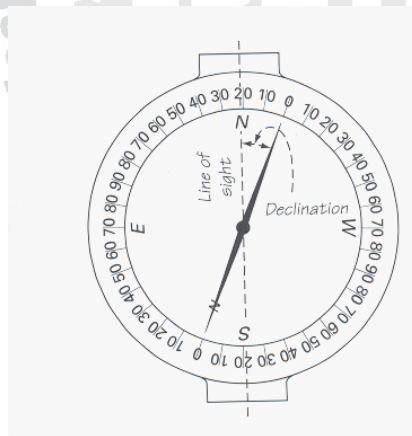

**Fig. 7.12.** Declination set off on a compass circle



The magnetic field is affected by metallic objects and direct-current electricity, both of which cause a local attraction. As an example, when set up besides an old-time street car with overhead power lines, the compass needle would swing toward the car as it approached, then follow it until it was out of an effective range.

If the source of an artificial disturbance is fixed, all bearings from a given station will be in error by the same amount. Angles calculated from bearings taken at station will be correct, however. Local attraction is present if the forward and back bearings of a line differ by more than the normal observation errors. Consider the following compass bearings read on a series of lines:

AB.....N24<sup>0</sup>15'W  
BA.....S24<sup>0</sup>10'E  
CD.....N60<sup>0</sup>00'E  
DC.....S61<sup>0</sup>15'W

Forward bearing AB and back bearing BA agree reasonably well, indicating that little or no local attraction exists at A or B. However, the bearings at D differ from corresponding bearings taken at C by roughly 1<sup>0</sup>15' to the west of north. Local attraction therefore exists at point D and deflects the compass needle approximately 1<sup>0</sup>15' to the west of north.

It is evident that to detect local attractions, successive stations on a compass traverse have to be occupied and forward and back bearings read, even though the directions of all lines could be determined by setting up an instrument only on alternate stations.

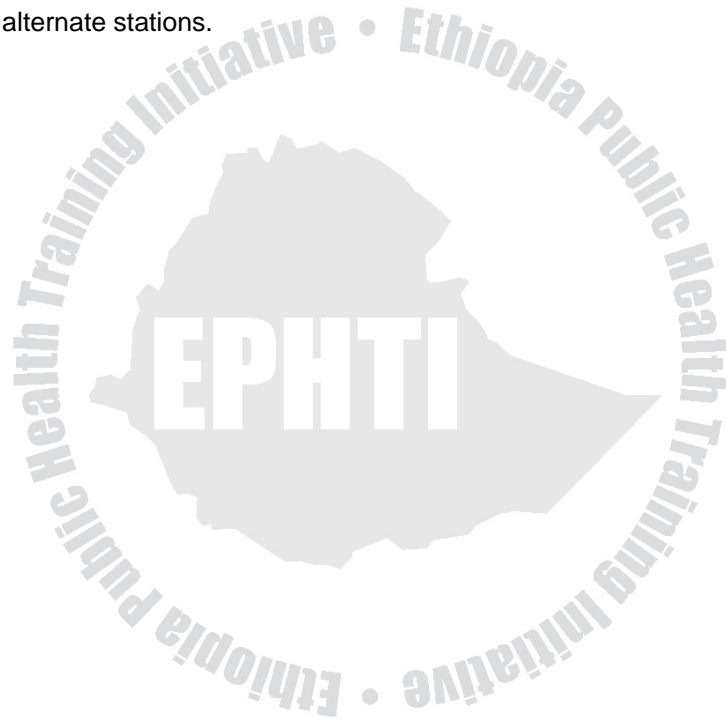

## Exercise

- The following azimuths are from the north;  $329^{\circ}20'$ ,  $180^{\circ}35'$ ,  $48^{\circ}32'$ ,  $170^{\circ}30'$ ,  $145^{\circ}25'$ . Express these directions as
  - Azimuths from the south
  - Back azimuths
  - Bearings
- The following are bearings:  $S21^{\circ}25'W$ ,  $N88^{\circ}42'W$ ,  $N69^{\circ}52'E$ ,  $S42^{\circ}25'E$ . Express these directions as:
  - Azimuths from north
  - Back azimuths
- The following azimuths are reckoned from the north.  $FE = 4^{\circ}25'$ ,  $ED = 90^{\circ}15'$ ,  $DC = 271^{\circ}32'$ ,  $CD = 320^{\circ}21'$  and  $BA = 190^{\circ}45'$ . What are the corresponding bearings? What are the deflection angles between consecutive lines?
- The interior angles of a five-sided closed polygon ABCDE are as follows.  $A = 120^{\circ}24'$ ,  $B = 80^{\circ}15'$ ,  $C = 132^{\circ}24'$ ,  $D = 142^{\circ}20'$ . The angle at E is not measured. Compute the angle at E, assuming the given values to be correct.

5. The magnetic bearings of a line is  $S47^{\circ}30'E$  and the magnetic declination is  $8^{\circ}20'E$ . What is the true bearing of the line?
6. In an old survey made when the declination was  $4^{\circ}15'E$ , the magnetic bearing of a given line was  $N35^{\circ}15'E$ . The declination in the same locality now is  $1^{\circ}10'W$ . What are the true bearings and the present magnetic bearing that would be used in retracing the line?

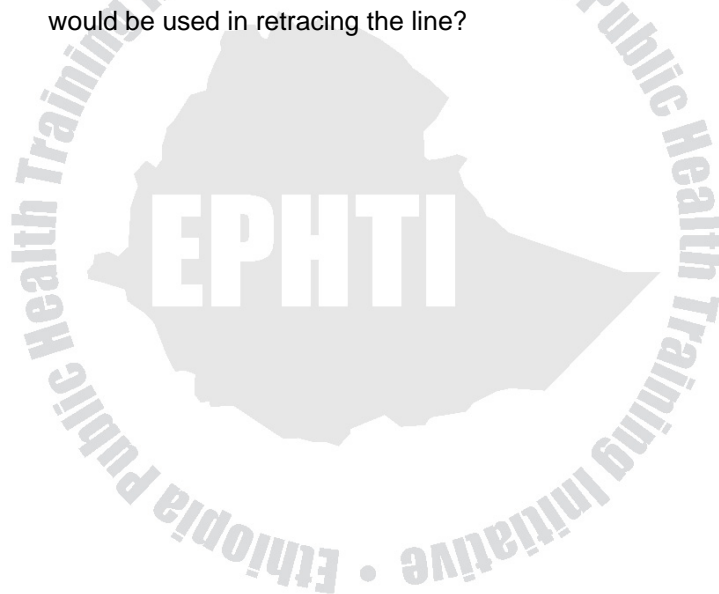

# CHAPTER EIGHT

## TRAVERSING

### 8.1. Learning Objectives

At the end of this chapter, the student will be able to:

1. Define and identify open and closed traversing
2. Mention and describe the general steps of traverse computation
3. Define the importance of traverse computation in omitted measurement
4. Compute area of plots by using different types of area computation techniques

### 8.2. Introduction

A traverse consists of an interconnected series of lines, called *courses*, running between a series of points on the ground, called *traverse stations*. A traverse survey is performed in order to measure both the distances between the stations and the angles between the courses.

Traverse is generally a control survey and is employed in all forms of legal and engineering works. It is a series of established stations that are tied together by angle and distance.

There are two types of traverse.

- Open – for route surveys
- Closed – for property surveys

Traverses are used to:

1. Locate topographic details,
2. Locate engineering works, and
3. Process and order earthwork quantities.

### A. Open Traverse

This is a series of measured straight lines that do not close geometrically. This lack of geometric closure means that there is no geometric verification for actual position of the traverse.

- ❖ Distances are measured twice and angles are doubled.

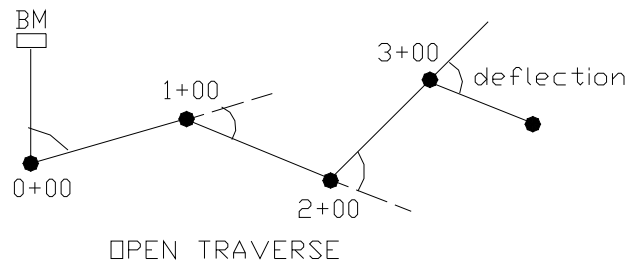

**Fig 8.1.** Open traverse

## B. Closed Traverse

Closed traverse is the one that either begins or ends at the same point or one that begins and ends at points whose positions have been previously determined.

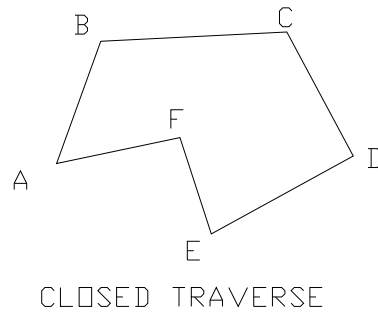

*Fig 8.2.* Closed traverse.

## 8.3. Balancing Angles

The geometric sum of interior angles in n-sided closed figure is  $(n-2)180$ . When all the interior angles of a closed field traverse are summed, they may or may not total the number of degrees required for geometric closure. This is due to systematic and random errors.

Before starting traverse computation, the angles should be balanced by distributing the angular error evenly to each angle.

The acceptable total error of angular closure is usually quite small (<03'); otherwise the fieldwork will have to be repeated.

## 8.4 Latitudes and Departures

We know that a point could be located by either polar co-ordinate or rectangular co-ordinate system. By definition, latitude is the north/south rectangular component of a line, and to differentiate directions, north is considered plus, whereas south minus. Similarly departure is the east /west rectangular component of a line.

When working with azimuths:

$$\text{Latitude } (\Delta Y) = \text{distance } (H) \cos \alpha$$

$$\text{Departure } (\Delta X) = \text{distance } (H) \sin \alpha$$

Where:

*$\alpha$  is the bearing or azimuths of the traverse course, and distance (H) is the horizontal distance of the traverse course.*

Latitudes (lats) and departures (deps) can be used to calculate the accuracy of a traverse by noting the plus/minus course of both lats and deps. If the survey has been performed, the plus latitudes will equal the minus latitudes, and the plus departures will equal the minus departures.



**N.B:** For azimuths directions the algebraic sign of the appropriate trigonometric functions governs the algebraic sign.

**Computation of Latitudes and Departures to Determine the Error of Closure and the Precision of a Traverse**

In the computation of latitudes and departures, the following steps should be followed.

1. Balance the angles.
2. Compute the bearings (azimuths).
3. Compute the latitudes( $\Delta y$ ) and departures( $\Delta x$ ).

For example, if the traverse computation begins at A and is concluded at A', the error of closure is given by the line A' A, and the correction of latitude (Clat) and the correction of departure (Cdep) are in fact the latitudes and departures of the linear error of closure.

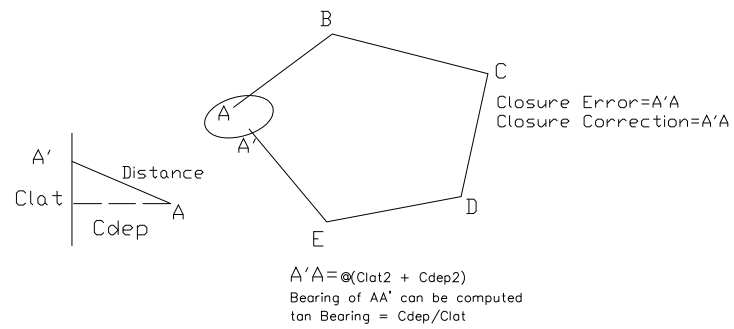

**Fig. 8.3.** Latitude and departure

The error of closure (linear error of closure) is the net accumulation of the random errors associated with the measurement of the traverse angles and traverse distances. It is accumulated at the station in which the computation begins. The error of closure is compared to the perimeter ( $P$ ) of the traverse to determine the *Precision ratio*.

$$\text{Closure Precision} = E/P = 1: P/E$$

## 8.5. Traverse Adjustment

Latitudes and departures can be used for the computations of co-ordinates or the computation of the area of enclosed by the traverse. However, before any further use can be made of these latitudes and departures, they must be adjusted so that their errors are suitably distributed, and the algebraic sums of the latitudes and departures are each zero.

There are two ways of traverse adjustment:

1. Compass (Bow ditch) rule-the common way
2. Transit rule: this is a complicated and lengthy procedure when done manually. It is now being applied by surveyors with increasing frequency when canned computer programs are used to adjust and close the traverse.

### Compass Rule

It Is Used In Many Survey Computations To Distribute The Errors In Latitudes And Departures. The Compass Rule Distributes The Errors In Latitudes And Departures For Each Traverse Course In The Same Proportion As The Course Distance Is To The Perimeter.

$$\frac{\sum \text{lat}}{\text{lat } AB} = \frac{AB}{P}$$

OR

$$\text{lat } AB = \sum \text{lat} \times \frac{AB}{P}$$

$$\frac{C_{dep} AB}{\sum dep} = \frac{AB}{P}$$

OR

$$C_{dep} AB = \sum dep \times \frac{AB}{P}$$

Where:  $C_{lat}/C_{dep}$  – corrections in latitude/departure AB

- $\sum lat, \sum dep$  are error of closures in lats and deps.
- AB –distance AB
- P-perimeter of the traverse.

*In both cases, the sign of the correction is opposite from that of the error.*

### **Effects of Traverse Adjustments on the Original Data**

Once the latitudes and departures have been adjusted, the original polar co-ordinates (distances and directions) will no longer be valid. In most cases, the adjustment required for the polar coordinates is too small; but if the data are to be used for layout purposes, the corrected distances and directions should be used. This process of obtaining new directions and lengths of the traverse are called *Inversing*.

$$Distances = \sqrt{Lat^2 + Dep^2}$$

$$Tan bearing = |dep/lat|$$

### Computation of Coordinates

The relative positions of control stations are best defined by their rectangular or XY coordinates.

Their rectangular coordinates best define the relative positions of control stations. In most surveying applications, the Y (north) coordinates precedes the X (east) coordinates. Coordinates of a point may be computed by successive algebraic addition of the adjusted latitudes and departures to the assumed N and E co-ordinates respectively.

$$N_2 = N_1 + Lat_{1-2}$$

$$E_2 = E_1 + Dep_{1-2}$$

Where:  $N_2$  and  $E_2$  are the Y and X co-ordinates of station 2

$N_1$  and  $E_1$  are the Y and X co-ordinates of station 1

$Lat_{1-2}$  = the latitudes of course 1-2

$Dep_{1-2}$  = the departure of course 1-2

## 8.6 Application of Traversing

### 8.6.1. Omitted Measurements

The techniques developed in the computation of latitudes and departures can be used to supply missing course information on a closed traverse and can be used to solve any problem that can be arranged in the form of a closed traverse.

The data can be treated in the same manner as in a closed traverse. When the latitudes and departures are totaled, they will not balance. Both the latitudes and departures will fail to close by the missing course.

$$\text{Distance} = \sqrt{(\text{Lat}^2 + \text{Dep}^2)}$$

$$\text{Tan bearing} = |\text{dep}/\text{lat}|$$

### 8.6.2. Area Of A Closed Traverse

#### BY THE COORDINATE METHOD

When the coordinates of the stations of a closed traverse are known, it is simple matter to compute the area within the traverse.

By definition, "the double area of a closed traverse is the algebraic sum of each X co-ordinates multiplied by the difference between the Y values of the adjacent stations."

The double area is divided by 2 to determine the final area. The final area can be positive or negative, reflecting only the direction of computation approach (C.W or C.C.W). But the area is always positive.

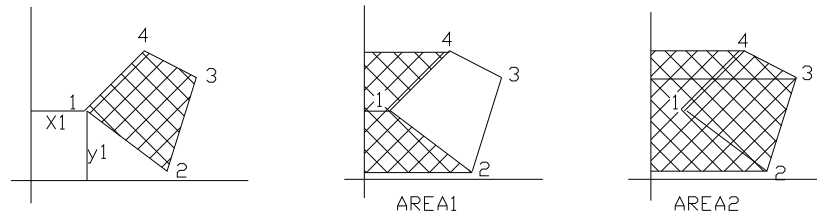

$$\text{AREA 1} = 1/2(X_4 + X_1)(Y_4 - Y_1) + 1/2(X_1 + X_2)(Y_1 - Y_2)$$

$$\text{AREA 2} = 1/2(X_4 + X_3)(Y_4 - Y_3) + 1/2(X_3 + X_2)(Y_3 - Y_2)$$

$$2A = X_1(Y_2 - Y_4) + X_2(Y_3 - Y_1) + X_3(Y_4 - Y_2) + X_4(Y_1 - Y_3)$$

**Fig. 8.4.** Area by rectangular coordinates

#### **By The Double Meridian Distance Method**

This method uses balanced latitudes and departures to directly calculate the area within a closed traverse. By definition, the meridian distance of a line is the distance from the midpoint of the line to some meridian.

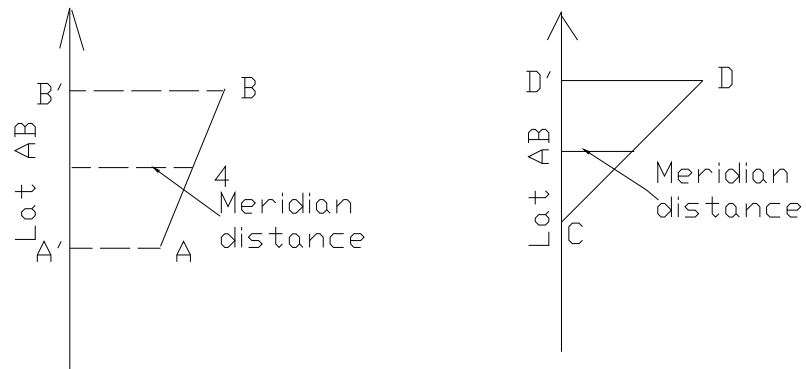

**Fig. 8.5.** Meridian distances and areas

Meridian distance (MD) of AB =  $(BB' + A'A)/2$

Area of trapezoid B'BAA' = Meridian distance AB X lat AB  
 $= (BB' + A'A)/2 * Lat AB$

$\therefore$  Area = Meridian Distance (MD) X Latitude

Double Area = Double Meridian distance (DMD) X latitude

$2A = DMD \times lat$

The total double area is first computed and then finally divided by 2 to get the required area.



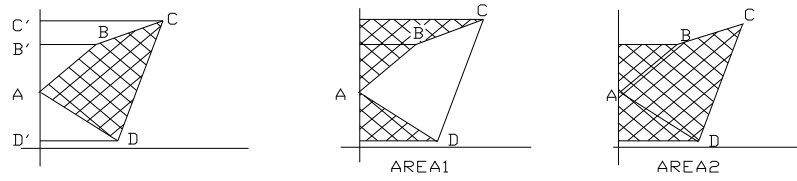

$$\text{AREA OF TRAVERSE} = \text{AREA2} - \text{AREA1}$$

**Fig. 8.6.** Area by double meridian distances

Generally, the computation for double area would proceed as follows.

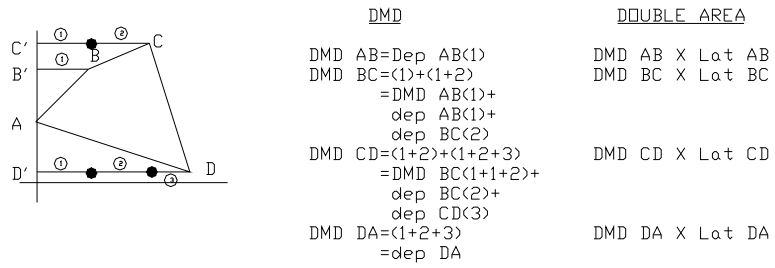

**Fig 8.7.** Double meridian distances

**N.B**

- ✓ The DMD of the first course is equal to the departure of the first course.
- ✓ The DMD of each succeeding course is equal to the DMD of the previous course + the departure of the previous course + the departure of the course itself.
- ✓ The DMD of the last course will turn out to be equal to the departure of the last course, but opposite in sign.

**Summary of Traverse Computations**

1. Balance the field angles
2. Correct (if necessary) the field distance (e.g. for temperature, sag)
3. Compute the bearings or azimuths
4. Compute the linear error of closure and the accuracy ratio of the traverse
5. Compute the balanced latitudes and balanced departures
6. Compute the coordinates
7. Compute the area by coordinate or by DMDs method

### 8.6.3 Mistakes in Traverse Computations

Some of the common mistakes made in traverse computations are:

1. Failing to adjust the angles before computing azimuths or bearings
2. Applying angle adjustment in the wrong direction and failing to check the angle sum for proper geometric total
3. Interchanging departures and latitudes, or their signs
4. Confusing the signs of coordinates
5. Carrying out corrections beyond the number of decimal places in the original measurements

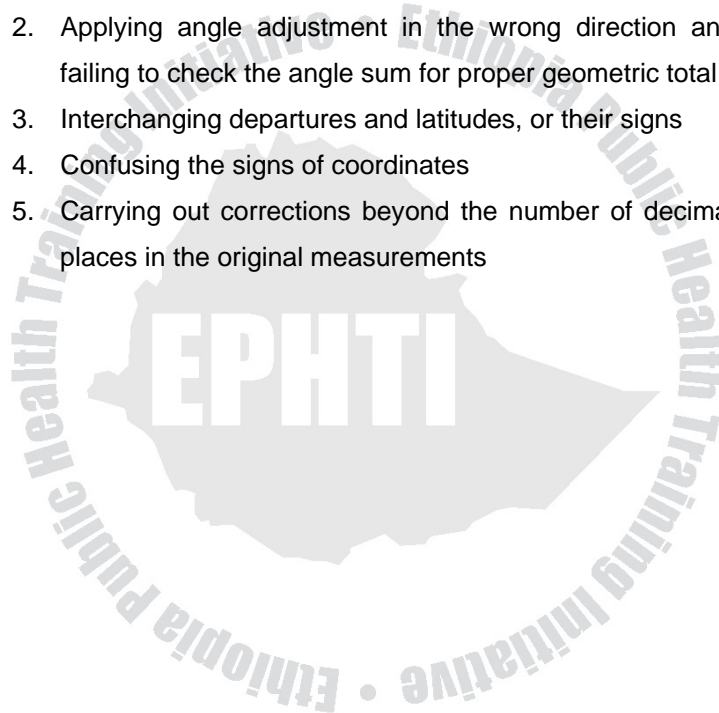

## Exercise

1. A five-sided closed field traverse have the following angles.  $A = 103^{\circ}03'30''$ ,  $B = 113^{\circ}44'00''$ ,  $C = 88^{\circ}21'30''$ ,  $D = 110^{\circ}53'30''$ ,  $E = 123^{\circ}55'00''$ . Determine the angular error of closure and balance the angles by applying equal correction to each angle.
  
2. A four-sided closed field traverse has the following angles.  $A = 81^{\circ}22'30''$ ,  $B = 72^{\circ}32'30''$ ,  $C = 89^{\circ}39'30''$ ,  $D = 116^{\circ}23'30''$ . The length of the sides are as follows:  $AB = 636.45\text{ft}$ ,  $BC = 654.49\text{ft}$ ,  $CD = 382.85\text{ft}$ ,  $DA = 512.77\text{ft}$ . The bearing of AB is  $533^{\circ}19'W$ , BC is in the SE quadrant.
  - a) Balance the field angles
  - b) Compute the bearing or the azimuth
  - c) Compute the latitude and departures
  - d) Determine the linear error of closure and the accuracy ratio
  - e) Balance the latitudes and departures by using the Compass rule.
  - f) Compute the coordinates of station A, C and D if the coordinate of station B are 1000.00N, 1000.00E

3. The following are stadia intervals and vertical angles to a theodolite stadia traverse. The elevation of station A is 150.485m. The stadia interval factor is 100 and  $C=0$ . Rod readings are taken at the height of the instrument.

Station	Azimuth	Interval, m	Zenith angle	Horizontal dist.	Difference in elev.	Elevation, m
A						150.485
B	85°06'	0.998	85°28'			
C	10°18'	1.895	86°08'			
D	265°00'	1.551	95°05'			
A	173°04'	1.857	92°10'			

- a) Calculate the horizontal distance for each line.  
 b) Determine elevation of transit station and distribute the error of closure in proportion to the distance.
4. Given the following notes for a closed-loop traverse, the coordinate of which for station A are  $X_A = 1,984,400.612\text{m}$ ,  $Y_A = 518,430.033\text{m}$ . Compute the error of closure and coordinate for each traverse station adjusted according to the compass rule.

Course	Azimuths	Distance, m
AB	0°42'	372.242
BC	94°03'	164.988
CD	183°04'	242.458
DA	232°51'	197.165

5. Given the following adjusted azimuths and measured distance for a close traverse that starts at C and closed on D. Compute
- The error of closure
  - The coordinates for each traverse station, adjusted by the compass rule;
  - Adjusted azimuths and distance for each line

Station	Azimuths	Distance, m	X, m	Y, m
C			16,118.900	31,852.440
1	210 <sup>0</sup> 43'34"	515.070		
2	275 <sup>0</sup> 08'30"	766.750		
3	283 <sup>0</sup> 09'15"	544.412		
4	231 <sup>0</sup> 23'14"	851.541		
5	174 <sup>0</sup> 22'28"	665.785		
D	252 <sup>0</sup> 32'20"	878.724	13,123.601	30,144.626

6. Adjusted plane coordinates for stations A and B are as follows.

Station	X, m	Y, m
A	12,275.645	33,444.604
B	15,486.166	34,178.809

Compute the distance and azimuths from A to B.

7. The following corners of a target trace of land were joined by the following open traverse:

Course	Distance, ft	Bearing
AB	80.32	N70°10'07"E
BC	953.83	N74°29'00"E
CD	818.49	N70°22'45"E

Compute the distance and bearing of the property frontage AD.

8. Given the following data for a closed property traverse
- Compute the missing data i.e. distance CD and bearing DE
  - Compute the area of the property bounded by the traverse by DMD method.

Course	Bearing	Distance, m
AB	N37°10'49"E	537.144
BC	N79°29'49"E	1109.301
CD	S18°56'31"W	?
DE	?	953.829
EA	N26°58'31"W	483.669

9. The following table gives X and Y coordinates (in meter) for stations in a closed traverse. Calculate the area enclosed by the traverse using the coordinate method.

Coordinates	Stations			
	A	B	C	D
X	4000	4100.5	4205.7	4103.4
Y	4000	4150.3	4875.0	4870.6

10. The following table gives the departure and latitudes of an adjusted closed traverse. Calculate the area by DMD method.

Course	Departures, m		Latitudes, m	
	+	-	+	-
AB		313.6		198.7
BC		274.4	281.1	
CD	189.2		134.1	
DE	110.7		324.9	
EA	288.1			541.4



# CHAPTER NINE

## CONSTRUCTION SURVEYS

### 9.1 Learning Objectives

At the end of this chapter, the student will be able to:

1. Describe the different types of construction surveys
2. Develop skills for construction of sewer and other constructions.

### 9.2. Introduction

Construction surveys provide the horizontal and vertical layout for every key component of a construction project. This provision of line and grade can only be accomplished by experienced surveyors familiar with both the related project design and the appropriate construction techniques. A knowledge of related design is essential to interpret the design drawings effectively for layout purposes, and a knowledge of construction techniques is required to ensure that the lay out is optimal for both line and grade transfer and construction schedule.

On any construction site, it is general practice to construct firstly the roadways and sewers, in order to provide a) access to the site and b) main drainage to all buildings.

All roads, buildings, drains and sewers are set out using standard surveying equipment comprising:

1. **Steel tapes:** it must always be used for setting out purposes as they are not subject to the same degree of stretching as are Fibron tapes. The accuracy of setting out work is largely dependent up on the condition of the tape and or course, the expertise of the user.
2. **Levels:** automatic levels are used on most sites. They compare favorably in price with optical levels and produce much more reliable results.
3. **Theodolites:** a wide variety of theodolite is now available but, as with levels, the more automation that can be provided, the greater will be the accuracy of the setting out. Thus, it is a good practice to use theodolite with optical plumbing, automatic vertical circle indexing, electronic readout and electronic two axis leveling.
4. **Total station:** most setting out work, particularly road ways, can be readily and accurately accomplished by the method of coordinates. An EDM instrument is required to set the distances and total stations can set out horizontal distances with ease.

5. **Autoplumb instruments:** These instruments are used to set a vertical line in high-rise buildings. They are much more convenient to use for this purpose than theodolites. They save much time and greatly increase accuracy.
6. **Pegs:** these are either wooden 50mm X 50mm X 500mm stakes for use in soft ground or 25mm X 25mm X 300mm angle irons for hard standing.
7. **Profiles:** is a wooden stake to which a cross-piece, painted in contrasting coloured stripes, is nailed. For sewer work, goalpost-type profiles, *called sight rails*, are preferable. The profiles are elected over the offset pegs in order to remain clear of the excavation.
8. **Travelers:** are really mobile profile boards used in conjunction with sight rails. The length of the traveler equals the sight rail level- sewer invert level. The length of 0.25 meters and travelers are usually about 2 meters long.
9. **Corner profiles:** during the construction of buildings, the pegs denoting the corners of the buildings are always removed during the construction work. The corner positions have, therefore, to be removed some distance back from the excavations on to corner profiles. These are constructed from stout wooden stakes 50mm X 50mm, on to which wooden boards 250mm X 25mm X 1.00m long are securely nailed.

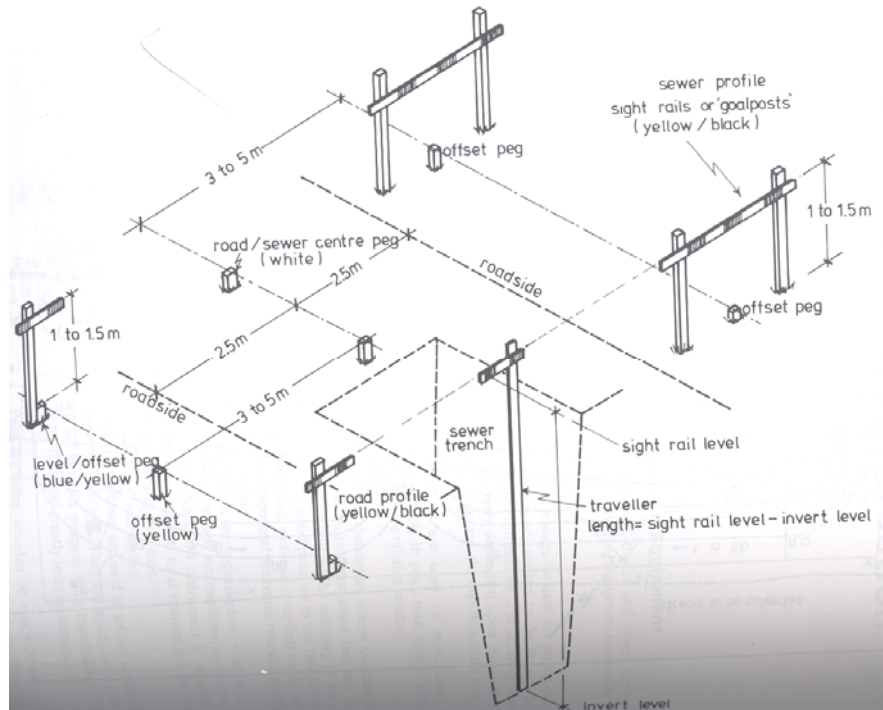

**Fig. 9.1.** Setting out pegs and profiles

### **9.3. Setting out a Peg on a Specified Distance and Bearing**

#### **A. Setting Out On Level Ground**

In order to set out the roads, buildings and sewers shown on the development plan, a total of some forty to fifty pegs need to be accurately placed on the ground in their proposed positions. Fortunately, every peg is set out in exactly the same manner. It is not an easy task to physically set a peg in its exact proposed location and, in order to do so, the following sequence of operations is required.

In figure 9.2a, a peg C is to be set out from a survey line AB. A surveyor and two assistants are usually required to complete the task.

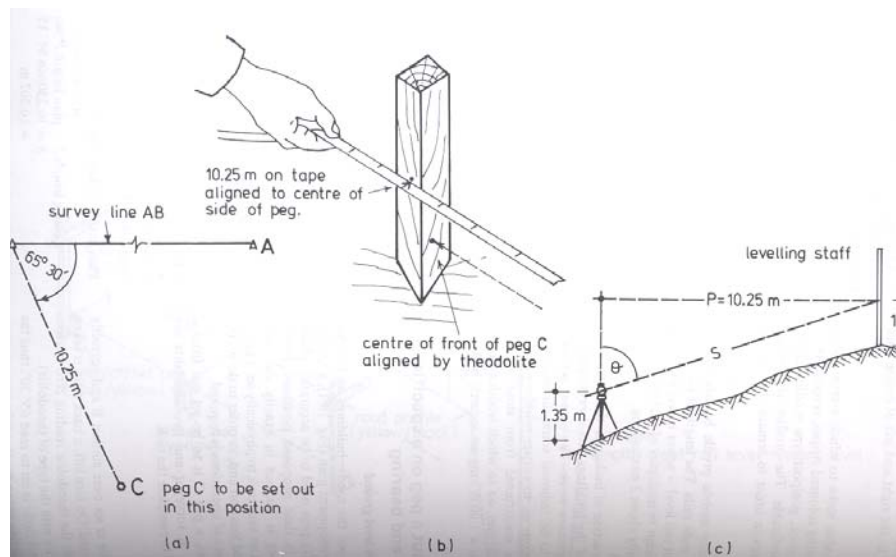

**Fig 9.2. Setting out on level ground**

**Procedure**

1. The theodolite is set over station B and correctly leveled and centered. On face left, a back sight is taken to station A with the type theodolite reading zero degrees (the method varies with the type of theodolite).
2. The horizontal circle is set to read  $65^{\circ}30'$ ; thus the theodolite is pointing along line BC.

3. The end of the tape is held against the nail in peg B and laid out approximately along the line BC by the assistants.
4. The 10.25 m reading on the tape is held against the SIDE of the proposed peg C (In figure 9.2b), the tape is tightened and slowly swung in an arc, until the surveyor sees it clearly through the telescope of the theodolite.
5. The peg is carefully moved, on the observer's instructions, until the bottom, front edge of the peg is accurately bisected. The peg is then hammered home.
6. The tape is again held at peg B, by assistant 1, while assistant 2 tightens it and marks a pencil line across the peg C at distance 10.25 m.
7. A pencil is held vertically on this line by an assistant and is moved slowly along the line until the surveyor sees it bisected by the line of sight through the theodolite. The assistant marks this point on the peg.
8. The distance of 10.25 m is checked and the operation is repeated on face right. If all is well, the two positions of point C should coincide or differ by a very few millimeters. The mean is accepted and a nail hammered into the peg to denote point C.

It is not good practice to hook the end of the tape over the nail at peg B when setting out the distance, as excessive tension on the tape will move the nail head or even move the peg.

### **B. Setting Out On Sloping Ground**

In all setting out operations, the horizontal distance is required, but frequently, because of ground undulations, it will be necessary to set out the slope distance. The setting-out procedure is very similar to that of setting out on a level ground.

1. The theodolite is set up at station B, back sighted to A reading zero and foresighted along the line BC reading  $65^{\circ}30'$ . The instrument height is measured and noted. Let the height be 1.35 m.
2. The tape is stretched out in the proposed direction of line BC and a leveling staff held vertically at distance 10.25 m.
3. The instrument height (1.35 m) is read on the staff and the angle of inclination (vertical or zenith angle) is noted. Let the zenith angle be  $84^{\circ}15'$ .
4. The distance to be set out on the slope will have to be increased to be the equivalent of 10.25 m of plan length, as follows (Figure 9.2c):



Plan length ( $p$ ) /slope length (S)

$$= \sin \text{zenith angle}$$

Slope length  $S = \text{plan length } p / \sin \text{zenith angle}$

$$S = 10.250 / \sin 84^{\circ} 15'$$

$$= 10.302 \text{ m}$$

5. The procedure in setting out peg C then follows exactly the procedure detailed in out on a level ground, using the new setting out length of 10.302 m.

#### **9.4. Setting Out Small Buildings**

Dwelling houses are still largely traditionally built and small inaccuracies in the setting out can usually be tolerated. Large factory buildings, multi-storey buildings, schools, etc., are nowadays largely prefabricated and little, if any, inaccuracy can be tolerated in the setting out. Consequently the methods of setting out vary considerably.

The exact position that the building is to occupy on the ground is governed by the building line as defined by the local authority.

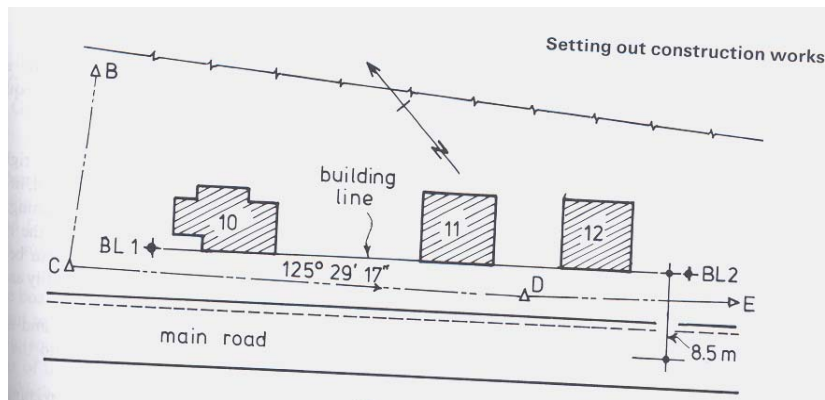

**Figure 9.3. Setting out small buildings**

In Figure 9.3, showing the development at the GCB outdoor Center, the building line is parallel to the main shore rod at a distance of 8.5 meters from the center line. The frontages of all three proposed buildings lie on this line. First, the building line must be established.

**(a) Setting out the building line-office work**

The building line may be set out by measuring two 8.5 m offsets to the north of the roadway center line or by scaling the coordinates of two points on the line and setting them out from an existing survey station by theodolite.

**(b) Setting out the building line – fieldwork**

1. Set the theodolite over peg C and take a back sight reading to D with the horizontal circle set to zero degrees (face left).
2. Set the horizontal circle to read  $336^{\circ} 46' 14''$  and set out and peg BL1 at distance 6.655 m.
3. Repeat the operation on face right as a check.
4. Transfer the theodolite to BL1 and take a back sight reading to C, with the horizontal circle set to zero degrees (face left).
5. Set the theodolite to read  $203^{\circ} 34' 13''$  and set out peg BL2 at distance 61.670 m.
6. Report the operation on face right as a check.

**(c) Setting out the building – fieldwork**

In figure 9.3. the three buildings fronting Shore Road have different shapes but, when setting out, each building is reduced to a basic rectangle, enabling checks to be easily applied.

Figure 9.3(a) shows the positions of house 10 Shore Rode and the relevant building line. The building may be set out from the building line using either (a) a steel tape or (b) some form of surveying instrument, usually a site square or optical square.

### Procedure

1. Using a scale rule, measure on the plan the distance between the building line starting point BL1 and the corner A of the house. The scaled dimension is 2.50 m.
2. Determine, from the plan, the dimensions of a basic rectangle to enclose the house. The scaled dimensions are 13.0 m by 8.0 m.
3. Using a steel tape set out the distance 2.50 m along the building line from point BL1, to establish corner A of the house. Mark the point by a nail driven into a wooden peg.
4. Measure the distance AB (13.0 m) along the building line and establish a peg at B. Mark the point by a nail.
5. Using a basic 3:4:5 right angle, measure the lengths AD and BC (8.0 m) and establish pegs at C and D.
6. Check the length of the diagonals AC and BD (15.264 m). Both measurements should be equal, thus providing that the building is square.

Although the method of setting out a right angle using a 3:4:5 triangle is theoretically sound, in practice it tends to lead to inaccuracy in positioning. By calculating the length of diagonal of the rectangle and using two tapes, the setting out can be accomplished.

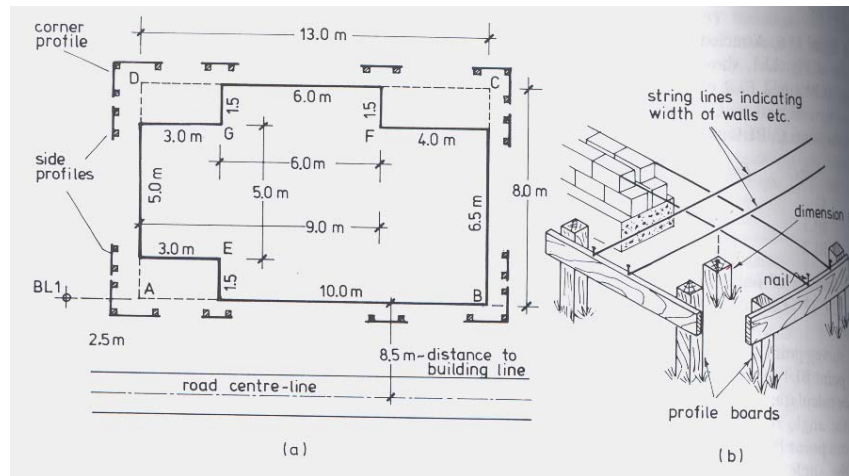

**Figure 9.4. Setting out the building**

### **Setting Out On Sloping Ground**

When setting out buildings on sloping ground, it must be remembered that the dimensions taken from the plan are horizontal lengths and consequently the tape must be held horizontally and the method of step taping used.

The diagonals must also be measured horizontally and in practice considerable difficulty is experienced in obtaining checks under such conditions. Besides, the method is laborious and time consuming.

It is possible to dispense with measuring the diagonals if a site square is used to set out the right angles at A and B (figure 9.5). The instrument is capable of setting out right angles with an accuracy of 1 in 2000.

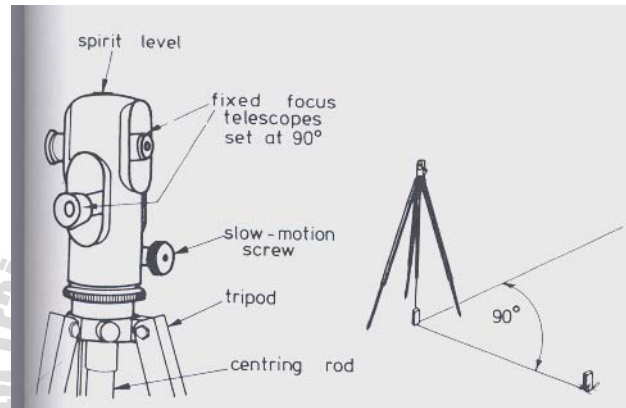

**Figure 9.5.** Setting out instrument on sloping ground

It consists of two small telescopes fixed rigidly at right angles on a small tripod. When the site square is set up at peg A the observer simply sights peg B through one telescope and lines in peg D through the other.

Similarly, peg C is set out from B and a check is provided on the work by erecting the instrument at D and checking that angle CDA is right angled.

- **Setting out – vertical control**

Whenever any proposed level is to be set out, sight rails (profiles) must be erected either at the proposed level in the case of a floor level or at some convenient height above the proposed level in case of foundation levels, formation levels and invert levels. Suitable forms of sight rails or profiles are shown in Fig 9.1. The rails should be set at right angles to the centre lines of drains, sewers, etc.

A traveler or boning rod is a mobile profile which is used in conjunction with sight rails. The length of the traveler is equal to the difference in height between the rail level and the proposed excavation level. Figure 9.1 shows the traveler in use in a trench excavation.

- **Setting out peg at a predetermined level**

The basic principle of setting out a profile board at a predetermined level is shown in figure 9.6.

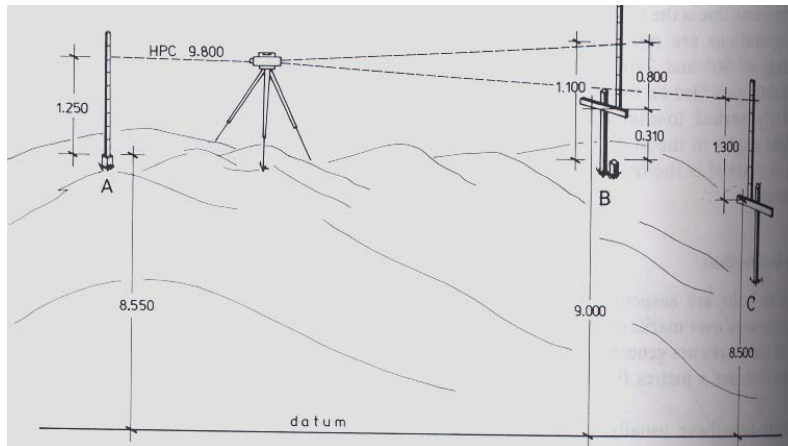

**Figure 9.6.** Setting out peg at a predetermined level.

Point A is a temporary bench mark (RL 8.55 m AD). Profile boards B and C are to be erected such that the level of board B is 9.000 m and that of board C is 8.500 m. These levels may represent floor levels of buildings or may represent a level of, say, 1.00 or 2.00 m above a drain invert level or a roadway formation level.

Setting up profile boards at different levels is the same operation and, once mastered, the methods may be used for any number of profiles on a site.

**(a) Procedure-method 1**

1. The observer sets up the leveling instrument at a height convenient for observing a site bench mark (RL



8.55 m AD) and takes a back sight staff reading (1.25 m). The height of collimation (HPC) is therefore

$$\text{RL Benchmark} + \text{BS Reading}$$

$$\text{i.e. HPC} = 8.55 \text{ m} + 1.25 \text{ m} = 9.80 \text{ m}.$$

- The assistant firmly hammers home a small peg, 300 mm long, besides the profile peg and a fore sight reading (1.11 m) is taken to a staff held vertically upon it. The level of the top of the small peg is therefore

$$\begin{aligned} \text{RL} &= \text{HPC} - \text{FS reading} \\ &= 9.80 - 1.11 = 8.69 \text{ m} \end{aligned}$$

- The difference in level between the top of the small peg (8.69 m) and the required profile level (9.00 m) is calculated:

$$\text{Difference} = 9.00 \text{ m} - 8.69 \text{ m} = 0.31 \text{ m}$$

Using a tape, the assistant measures this height against the profile peg and marks it in pencil.

- A profile board is nailed securely to the profile peg, such that the upper edge of the board is against the pencil mark, and is thus at a level of 9.00 m.

This method is widely used on construction sites because of its simplicity. However, it has the disadvantage that the observer has to rely upon the assistant (often untrained) to

correctly mark the final height on the profile peg. The disadvantage is overcome by using the following method.

**(b) Procudre-method 2**

1. The observer sets up the leveling instrument, takes a back sight to the benchmark and computes the height of collimation (HPC) as before;

$$\begin{aligned} \text{HPC} &= \text{RL benchmark} + \text{BS reading} \\ &= 8.55 \text{ m} + 1.25 \text{ m} = 9.80 \text{ m} \end{aligned}$$

2. The staff man holds the staff against the profile peg and moves it slowly up or down until the base of the staff is at a height 9.00 m, exactly. This will occur when the observer reads  $9.80 \text{ m} - 9.00 \text{ m} = 0.80 \text{ m}$  on the staff, since

$$\text{HPC} = 9.80 \text{ m}$$

$$\text{Required profile level} = 9.00 \text{ m}$$

$$\text{Therefore staff reading} = 0.80 \text{ m}$$

3. The base of the staff is marked in pencil against the profile peg and the profile board is nailed securely to the peg, such that the upper edge of the board is against the pencil mark.

4. Profile board C is established in exactly the same manner, but since the board is to be erected at a different level, a new calculation is required;

$$\text{HPC} = 9.80 \text{ m}$$

$$\text{Required profile level} = 8.50 \text{ m}$$

$$\text{Therefore staff reading} = (9.80 - 8.50) \text{ m} = 1.30 \text{ m}$$

- C. The observer sets up the leveling instrument, takes a back sight to the bench mark and computes the height of collimation (HPC).

## 9.5. Sewer and Tunnel Construction

Sewers can be categorized into two broad categories:

1. Sanitary sewers collect residential and industrial liquid waste and convey these wastes (sewage) to a treatment plant.
2. Storm sewers are designed to collect runoff from rainfall and to transport this water (sewage) to the nearest natural receiving body (e.g. River, lake). The rain water enters the storm sewer system through ditch inlets or through catch basins located at the curb line on paved roads.

The design and construction of sanitary and storm sewers are similar in the respect that the flow of sewage is usually governed by gravity. Since the sewer grade lines (flow lines)

depend on gravity, it is essential that the construction grades be precisely given.

The sewers usually located 5 feet (1.5m) either side of the road. The sanitary sewer is usually deeper than the storm sewer. As it must be deep enough to allow for all house connections. The sanitary house connection is usually at 2 % (minimum) slop. If sanitary sewers are being added to an existing residential road, the preliminary survey must include the basement floor elevations. The floor elevations are determined by taking a rod reading on the windowsill and then, after getting permission to enter the house, measuring from the windowsill down to the basement floor. As a result of deep basements and long setbacks from the main road, sanitary sewers often have to at least 9 ft (2.75m) below the main road.

The depth of storm sewers ranges from 3 ft(1m) in some area of the south to 8 ft (2.5m) in the north. The design of the inlets and catch basins depends on the depth of sewer and the quality of the effluent.

The minimum slop for storm sewers is usually 0.50%, where as the minimum slop for sanitary sewer is often set at 0.67%. in either case , the designers try to achieve self cleaning velocity 2.5 to 3 ft per second ( 0.8to 0.9m/s) to avoid excessive sewer maintenance costs.

Manholes (maintenance holes) are located at each change in direction, slope, or pipe size. In addition, manholes are located at 300 to 450 ft (100 to 140m) intervals maximum.

Catch basins for storm water are located at 300 ft (100m) maximum intervals; they are also located at the high side of intersections and at all low points. The 300 ft (100m) maximum interval is reduced as the slope on the road increases.

For construction purpose, sewer layout is considered only from one man hole to the next. The stationing (0+00) commences at the first (existing) man hole (or outlet) and proceeds only to the next man hole. If a second leg is also to be constructed, that station of 0+00 is assigned to the downstream manhole and proceeds upstream only to the next manhole. Each manhole is described by a unique manhole number to avoid confusion with the stations for extensive sewer projects.

#### **Tunnel construction**

Tunnels are used in road, sewer and pipeline construction when the cost of working at or near the ground surface becomes prohibitive. For example, sewers are tunneled when they must be at a depth that would make open cut too expensive or (operationally unfeasible) , or sewer may be

tunneled to avoid disruption of services on the surface such as would occur if an open cut was put through a busy expressway. Roads and railroads are tunneled through large hills and mountains in order to maintain optimal grade lines.

### **Building construction**

All buildings must be located with reference to the property limits. Accordingly, the initial stage of the building construction survey involves the careful retracing and verification of the property lines. Once the property lines established, the building is located according to plan, with all corners marked in the field. At the same time, original cross sections will be taken, perhaps using one of the longer wall lines as a base line.

## Exercise

1. Mention the different types of construction surveys.
2. Explain the use of the following surveying equipments.
  - a. Levels
  - b. Theodolite
  - c. Autoplumb instrument
  - d. Profiles
3. Describe the difference of setting pegs on level and sloping ground.
4. Describe the difference between sanitary and storm sewers.
5. Discuss the relevant points that are used on layout of sewers.
6. The floor levels of a split level houses are upper level 22.500m AD and lower level 24.300m AD. They are to be set out in relation to a near by bench mark (23.870mAD). Table 9.1 shows the relevant readings. Calculate the staff readings x and y required to setout profiles at both floor levels.

Table 9.1. Readings

BS	IS	FS	HPC	Required level	Remark
2.360				23.870	Bench mark
	X			25.500	Upper floor level
		y		24.300	Lower floor level

## GLOSSARY

**Accuracy:** The conformity of the measurement to the true value.

**Alignment:** the location of centerline of a survey or a facility.

**Arithmetic Check:** a check in the reductions of differential leveling involving the sums of back sight and foresights.

**Automatic level:** A surveyor's level in which line of sight is automatically maintained in the horizontal plane, once the instrument is roughly leveled.

**Azimuth:** the angle to a line of sight, measures clockwise (usually) from a north meridian.

**Back sight:** A sight taken with a level to a point of known elevation, thus permitting the surveyor to compute the elevation of the HI. In transit work, the back sight is a sighting taken to a point of known position to establish a reference direction.

**Base line:** A line of reference for survey work; often the center line, the street line, or the center line of construction is used, although any line could be arbitrarily selected or established.



**Batter Boards:** Horizontal crosses pieces on grade stakes or grade rods that refer to the proposed elevation.

**Bearing:** Direction of a line given by the acute angle from a meridian and accompany by a cardinal compass direction.

**Bench mark:** a relatively permanent object, natural or artificial, is having a marked point whose elevation above or below an adopted datum.

**Construction Survey:** Provision of line and grade.

**Contour:** A line on a map joining points of similar elevation.

**Control Surveys:** Surveys taken to establish reference points, elevations and lines for preliminary and construction surveys.

**Cross section:** a profile of the ground and surroundings taken at right angles to a reference line.

**Cut:** In construction, the excavation of material; also the measurement down from a grade mark.

**Datum:** An assumed or fixed horizontal reference plane.

**Deflection angle:** the angle between the prolongation of the back line measured right (R) or left (L) to the forward line.

**Departure:** The change in easterly displacement of a line ( $\Delta E$ ).

**Differential Leveling:** Determining the differences in elevation between points using surveyor's level.

**Double Centering:** A technique of turning angles or producing straight lines involving a minimum of two sightings with a theodolite. Once with the telescope direct and once with the telescope inverted.

**Drainage:** The collection and transportation of ground and storm water.

**Elevation:** the vertical distance from a vertical datum, usually sea level, to a point or object.

**Fill:** Material used to raise the construction level; also the measurement up from a grade mark.

**Foresight:** In leveling, a sight taken from a BM or TP to obtain a check on a leveling operation or to establish a transfer elevation.

**Free Station:** A conveniently located instrument station used for construction layout, the position of which is determined after occupation through resection techniques.

**Gradient:** The slope of a grade line.

**Gunter's Chain:** Early (1800s) measuring devices consisting of 100 links, measuring 66ft long.

**Horizontal plane:** a plane perpendicular to the direction of gravity. In plane surveying, a plane perpendicular to the plumb line.

**Horizontal line:** a line in a horizontal plane. In plane surveying, a line is perpendicular to the vertical.

**Intermediate Sight:** A sight taken with a level or transit to determine a feature elevation and or location.

**Lay out Survey:** Construction surevey.

**Level surface:** a curved surface that at every point is perpendicular to the local plumb line (the direction of gravity acts). They are approximately spheroid in shape.

**Level line:** a line in a curved surface.

**Leveling:** the process of finding elevations of points, or their difference in elevation.

**Latitude (of a course):** The change in northerly displacement of a line ( $\Delta N$ )

**Latitude (geographic):** angular distance from the earth's center, measured northerly or southerly from the equatorial plane.

**Line and Grade:** The horizontal and vertical position of a facility.

**Linear Error of Closure:** The line of traverse misclosure representing the resultant of the measuring errors.

**Longitude:** angular distance measured in the plane of the equator from the reference meridian through Greenwich, England. Lines of longitude are indicated on globes as meridians.

**Mean sea level:** The average height of the sea's surface for all stages of tide over a 19-years period.

**Meridian:** A north-south reference line.

**Mistake:** a poor result due to carelessness or misunderstanding.

**Normal Tension:** The amount of tension required in taping to offsets the effects of Sag.

**Original Ground:** The position of the ground surface prior to construction.

**Page Check:** Arithmetic Check.

**Planimeter:** A mechanical or electronic device used to measure areas by tracing the outline of the area on the map or plan.

**Precision:** The degree of refinement with which a measurement is made.

**Property Survey:** A survey to retrace or establish property lines, or to establish the location of buildings within the property limits.

**Station:** A point on a base line that is a specified distance from the point of commencement. The point of commencement is identified as 0+00; 100 ft or 100m are known as full stations (1000m in some highway applications); 1+45.20 identifies a point distant 145.20 ft or m from the point of commencement.

**Traverse:** a continuous series of measured (angle and distance) lines.

**Three-wire leveling:** A more precise technique of differential leveling in which rod readings are taken at the stadia hairs, in addition to the main cross hair.

**Total Station:** An electronic theodolite combined with an EDM and an electronic data collector.

**Turning Point:** In leveling a solid point where an elevation is temporarily established so that the level may be relocated.

**Vertical Angle:** An angle in the vertical plane measured up (+) or down (-) from the horizontal.

**Vertical control:** a series of bench marks or other points of known elevation established through out an area, also called *basic control* or *level control*.

**Vertical datum:** any level surface to which elevations are referred. Also called *vertical datum plane*.

**Vertical line:** a line that follows the direction of gravity as indicated by a plumb line.

**Vertical plane:** At a point is any plane that contains the vertical line at the point. There are unlimited number of vertical planes at a given points.

**Waving the rod:** The slight waving of the leveling rod to and from the instrument, which permits the surveyor to take a precise (lowest) rod reading.

**Zenith Angle:** Vertical angle measured down ward from the Zenith (Up wards plumb line) direction.

## REFERENCES

1. Barry F. Kavanagh and S.J. Glenn Bird, Surveying Principles and Applications, 5<sup>th</sup> edition, 2000.
2. Paul R. Wolf and Russell C. Brinker, Elementary Surveying, 9<sup>th</sup> edition, 1994.
3. James M. Anderson and Edward M. Michael , Surveying Theory and Practice, 7<sup>th</sup> Edition, 1998
4. William Irvine, Surveying for Construction, 4<sup>th</sup> Edition, 1995
5. Nathanson Kissam, Surveying Practice, 4<sup>th</sup> Edition, 1988
6. Francis H. Moffitt, Surveying, 8<sup>th</sup> ed. 1987.
7. R.Agor, A text book of Surveying and Leveling, 9<sup>th</sup> ed. 2003.